

## HEIs service quality as a predictor of students' satisfaction affecting academic performance: The extension of the Embryonic HESQUAL model

Kamrunnahar Happy<sup>a\*</sup>, Nafiza Islam<sup>b</sup> and Rabbir Rashedin Trino<sup>b</sup>

<sup>a</sup> European University of Bangladesh, Bangladesh

<sup>b</sup> Jahangirnagar University, Bangladesh

### CHRONICLE

*Article history:*

Received: December 20, 2023

Received in revised format:

January 26 2024

Accepted: March 20, 2024

Available online:

March 20 2024

*Keywords:*

Higher education

HESQUEL

Service quality dimensions

### ABSTRACT

To question the dominance of the dimensions of service quality using the embryonic HESQUAL model on students' satisfaction. Besides, the study will identify the mediating effect of a department's commitment and a moderating effect of self-efficacy on the relationship between students' satisfaction and academic performance. The study was a one-time dimensional and used a simple random sampling method which is suitable for quantitative statistical analysis and homogeneous populations in nature. Analysis resulting from SmartPLS by using 431 responses from undergraduate and graduate students of public universities in Bangladesh. The study found that students are focused on core educational qualities and physical environmental facilities to be satisfied. Thoroughly, students' satisfaction has a direct impact on academic performance but surprisingly no moderating precedence of self-efficacy on the connection between student satisfaction and academic performance was seen. Noticeably, the extension of the HESQUAL model of department commitment finds significant influences on both satisfaction and academic performance. However, the modified HESQUEL will quantify the quality dimensions in higher education, and its application in this study can depict a greater understanding of the quality dimensions required to be prioritized by university authorities and policymakers.

© 2025 by the authors; licensee Growing Science, Canada

## 1. Introduction

New ways of thinking and comprehensive approaches become an absolute must for all sorts of organizations in order to survive in the atmosphere categorized by rapid changes in terms of technology, customer needs and preferences, social structure, and government regulation which has created a new dimension of quality as well as the literature identified higher education as competitive as well dynamic (Krücken, 2021; Lynch, Gottfried, Green, & Thomas, 2023). Higher education institutions (HEIs) are currently credited with playing a vital role in the economy as they are turning into businesses and also have performance indicators for accountability and quality assurance. On the other hand, students are the prime customers in education, and overseeing the service quality in higher education is required (Liu, Bao, Zhao, Sang, & Fu, 2022). For this sake, they ought to be more focused on improving students' experience and satisfaction as the key stakeholders (Abbas, 2020).

University education is a means for creating individuals in order to serve the different economic sectors with academic and psychological competence (Granovetter, 2018). Furthermore, the needs and demands of the industrial and service industries have changed during the last three decades as a result of major developments in technology, the labor market, and workforce structure. Higher education institutions were also altered as operating circumstances required change (Abbas, 2020). HEIs typically receive more attention, support, and priority treatment from most of the world's most economically advanced nations. HEIs must have a deep understanding of what influences student satisfaction and improvement (Sharabati, Alhileh, &

\* Corresponding author.

E-mail address: [happykamrunnahar007@gmail.com](mailto:happykamrunnahar007@gmail.com) (K. Happy)

Abusaimh, 2019). Numerous studies have shown that providing exceptional service produces an auspicious image in the eyes of students, which leads to student gratification (Akareem & Hossain, 2016; Khalifa, et al., 2021; Naidu, 2021). It is not pointing at the academic issues only (Zhao 2003) addressed students' satisfaction considered with the contentment of course quality, instructor contact, peer collaboration, and support services.

Quality has been extended from industry to service, but not to higher education. TQM, a prominent concept in quality management, has been the subject of numerous research in higher education; yet, there is a noticeable lack of effective, practical, and complete quality management methodologies in higher education (Jasti, Venkateswaran, & Kota, 2021). Moreover, the whole system is experiencing challenges for the sake of economic challenges globally (Rozak, et al., 2022). On the other hand, due to the large amount of diversity among students in HEIs, vagueness and uncertainty take place to ensure the quality of service (Liu, Bao, Zhao, Sang, & Fu, 2022; Rozak, et al., 2022). With the increasing demand of the stakeholders of the universities, Bangladesh is also experiencing challenges to provide better education as the educational sector is competing not only locally but globally (Hosen, Uddin, Hossain, Islam, & Ahmad, 2022). According to a recent study, education experts and scholars claimed that the quality of higher education had gradually deteriorated over the past two decades. One of the main reasons for these deteriorations is the imperfectly assessed quality of higher education services (Muhibullah, Mamun, & Afroz, 2021). Therefore, the department can also make the contribution to satisfy the student satisfaction and improve their academic performance.

Apart from this background, this study attempts and is designed to explore the dominance of service quality on students' satisfaction. Furthermore, the study will determine the impacts of student satisfaction on academic performance through the department's commitment and a moderator of self-efficacy, which will be an extension of the previous model.

## 2. Literature Review

### 2.1 *Quality Measurement Aspects in Higher Education Institutions (HEIs)*

HEI can be viewed as part of the training phase and should focus on education quality in order to develop the quality of the real work environment. Excellent education displays an institution's potential to be a tool for a nation's economic growth by educating the younger generation to a better level (Anis & Abdullah, 2014). Researchers continually examine the value of services to measure service standards (Afthanorhan, Zainudin Awang, Foziah, & Liza, 2019). There is no universal agreement on how to evaluate HEIs due to various diverse scholarly concepts (Dwaikat, 2021). (Cheng & Tam, 1997) identified in the literature on management, various scholars denote quality differently like value (Feigenbaum, 1951), conformance to specifications, conformance to requirement and defect prevention (Crosby, 1979), suitability for use (Juran & Gryna, 1993), quality as excellence (Peters & Robert H. Waterman, 1982), meeting customer expectations (Parasuraman, Zeithaml, & Berry, 1985) and so on. Moreover, the quality of education consists of both disciplines and substantive resources which make them competent in the marketplace (Sharabati, Alhileh, & Abusaimh, 2019).

Besides this prominent model of SERVQUAL concerning customer satisfaction, only a few tried to sketch out the service quality dimensions in higher education. Notwithstanding in today's competitive era, improving service quality in higher education is the most challenging task (Teeroovengadum et al., 2016). Consequently, Teeroovengadum et al. (2016) proposed a model to assess service quality in higher education with five dimensions (administrative quality, support facilities quality, core educational quality, and physical environment quality) namely the HESQUAL model. Afterward, Teeroovengadum et al. (2019) strongly recommend the five dimensions of service quality such as administrative quality, core educational quality, transformative quality, support service quality, and physical environment quality. Subsequently, validated the HESQUAL scale and depicted an improved structural model which predicts students' loyalty from the image, perceived value, satisfaction, and service quality.

However, (Parasuraman, Zeithaml, & Berry, 1985) pioneered the evaluation of service quality, aside from the well-known SERVQUAL model for customer satisfaction, only a few have attempted to sketch out the service quality characteristics in HEIs. In today's competitive environment, enhancing service quality in higher education is the most difficult task (Teeroovengadum, Kamalanabhan, & Seebaluck, Measuring service quality in higher education: Development of a hierarchical model (HESQUAL), 2016). Consequently, (Teeroovengadum, Kamalanabhan, & Seebaluck, Measuring service quality in higher education: Development of a hierarchical model (HESQUAL), 2016) introduced the HESQUAL model to assess service quality in higher education across five domains (administration quality, support facility quality, core educational quality, and physical environment quality) and strongly advocated these dimensions. Following that, the HESQUAL scale was validated, and an enhanced structural model was illustrated that predicts student loyalty based on image, perceived value, satisfaction, and service quality.

### 2.2 *Research Framework and Hypothesis Development*

This study sketches a framework with an extended HESQUAL model for students' satisfaction and perceived academic performance. Despite the fact that there were five sub-dimensions of service quality, the study uses four dimensions of service quality in the HESQUAL model: administrative quality, core educational quality, transformative quality, and physical environment quality toward students' satisfaction while ignoring support service quality (see Figure 1). In the context of Bangladesh, many researchers found poor support service quality with a lack of IT facilities. Moreover, the canteen and recreation

facilities have no direct or indirect effect on students' satisfaction in the Bangladeshi context (Alauddin, Ahsan, Kamal, Alam, & Hassan, 2020).

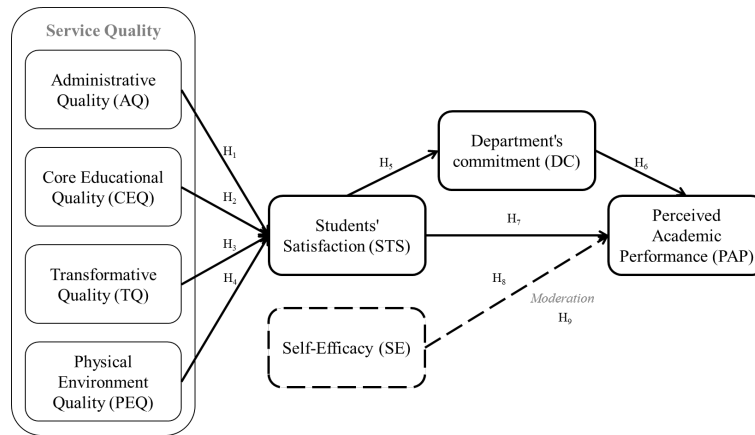

**Fig. 1.** Conceptual framework

In the case of tangible quality, private university students are more furnished and facilitated than in public universities, as well as most researchers found a significant effect for private HEIs (Hossain, Hossain, & Chowdhury, 2018). Considering those issues and together with validation for support service facilities, the researcher omits the dimension. Subsequently, the ultimate endogenous variable is students' academic performance as well as the department's commitment to working as an exogenous variable towards student satisfaction and academic performance. Additionally, there is a moderating effect on self-efficacy.

### 2.2.1 Perceived Service Quality and Student Satisfaction

Service quality is linked with customer satisfaction, and it prescribes the comparison between perceived service expectations and perceived performance (Cahyono, et al., 2020). Hence, service quality can be described in the context of HEIs as the gap between what a student expects to receive and their perceptions of the real perception (Teeroovengadum, Kamalanabhan, & Seebaluck, 2016). Although there is an argument, students tend to think of themselves as customers. As in other segments of higher education, students are satisfied when their expectations exceed or are met. Even the debate is also present about the student's needs (Brooks, Gupta, Jayadeva, & Abrahams, 2021). It has been said that quality services provided to customers bring in the future or customer satisfaction leads to customer retention. In other words, student satisfaction leads to increased loyalty and improved performance. Overall, satisfaction is influenced by the dimensions of service quality (Singh & Jasial, 2021).

(Gao, 2020) alluded that the phenomenon of the university may be classified into two categories: one is teaching, and the other is administrative. Administrative functions support teaching affairs to achieve the goal of a university. Students in a university administrative staff must have attributes such as responsiveness, dependability, a caring attitude, fairness, accuracy, respect, and cooperation. Despite the fact that the majority of studies support this insignificance and lack of these attributes (Weerasinghe & Fernando, 2018). On the other hand, (Azam, 2018) confirms the significant influence of administrative services on students' satisfaction in an HEI. Moreover, a causal relationship exists between administrative services and satisfaction. (Dhawan, 2022) also identified a link between administrative quality and student satisfaction.

**H<sub>1</sub>:** *Administrative quality has a significant positive impact on students' satisfaction.*

The next dimension is core education which is comprehensive in nature. This does not only involve basic or threshold training but also focuses on the theories, concepts, and skills needed in teaching and teaching mediators (Nguyen, Pham, Cao, Nguyen, & Do, Investigating the impacts of core educational quality on the satisfaction and loyalty of parents of secondary school students: The mediating role of transformative quality, 2021). A study on public sector universities in Thailand was conducted to explore the students' satisfaction with service quality and found a significant influence of their core educational quality on students' satisfaction. This implies that they are trying to give more attention to fulfilling their students' priorities and needs (Ali, Shah, & Mangi, 2019). Overall, improving curriculum and teaching quality also leads to higher satisfaction (Dhawan, 2022).

**H<sub>2</sub>:** *The core educational quality has a significant positive impact on students' satisfaction.*

Another important dimension of service quality is the transformative quality which reflects the empowerment and improvement of students. Here, improvement denotes not only the gathering of knowledge but also the qualitative transformation to become a knowledge learner (Nguyen, Pham, Cao, Nguyen, & Do, Investigating the impacts of core educational quality on the satisfaction and loyalty of parents of secondary school students: The mediating role of transformative quality, 2021). This dimension is used in several research papers to measure the students' perceived service quality (Teeroovengadum, Kamalanabhan, & Seebaluck, Measuring service quality in higher education: Development of a hierarchical model (HESQUAL), 2016). Furthermore, transformative quality has a significant influence on student satisfaction (Ali, Shah, & Mangi, 2019).

**H<sub>3</sub>:** *The transformative quality has a significant positive impact on students' satisfaction.*

Notwithstanding, there is a saying that the quality of the physical environment is grounded on a hidden curriculum in higher education that is not openly intended but transmitted values, norms, and beliefs (Tor, 2015). Conversely, physical environment quality is another important predictor and plays a vital role in student satisfaction (Ali, Shah, & Mangi, 2019; Dhawan, 2022; Han, Kiatkawsin, & Kim, 2018). The learning environment is being updated, the old physical environment is taking place in digital format, and students are more satisfied with new facilities such as classrooms, IT facilities, and the library, as well as workplace and classroom capacity, which could be identified (Mercredi, 2021).

**H<sub>4</sub>:** *The physical environment quality has a significant positive impact on students' satisfaction.*

### 2.2.2 Student Satisfaction and Academic Performance

Students are the most important asset in any educational institution. There is no value in any educational institution without students. Not only that the social and economic progress of any country is largely dependent on them being great leaders and workforce for the country and that depends on the performance of a student and the performance of the students depends on their satisfaction (Dhaqane & Afrah, 2016). Additionally, various factors influence students' academic achievement in higher education (socioeconomic, psychological, environmental, etc.) among those factors' student satisfaction is the most crucial that influences students' academic performance (Martirosyan, Saxon, & Wanjohi, 2014). Many scholars believe that service quality is also an important factor in student satisfaction (Sharabati, Alhileh, & Abusaimh, 2019). Academic achievement (GPA), on the other hand, is a key predictor of student satisfaction, and many experts believe there is a recursive relationship between them. (Umbach & Porter, 2002)

**H<sub>5</sub>:** *Student satisfaction has a significant positive impact on students' perceived academic performance.*

### 2.2.3 Department's Commitment and Student Satisfaction

Being mentally or intellectually dedicated to some action concerning one person's relationship with another person, group, or organization, is about what commitment entails (Raheem, 2009). (Fan & Prasongsukarn, 2019) revealed the relationship between the department's commitment and student satisfaction is not significant. Although department commitment does not influence student satisfaction, it does influence feedback and improvement about what they experienced (Ardi, Hidayatno, & Yuri M. Zagloel, 2012). The literature supports that both individual and environmental prominence impact student satisfaction. From the individual factors, academic departments have an important influence on student satisfaction. Subsequently, the important outcome of student satisfaction is intellectual and personal development (Umbach & Porter, 2002). Here, the individual effect will be considered department commitment and we predicted that a significant relationship would exist.

**H<sub>6</sub>:** *The Department's commitment has a significant positive impact on students' satisfaction has a significant positive impact on.*

### 2.2.4 Department's Commitment and Student Academic Performance

Commitment is a key component of any effective organization especially in service organizations such as educational institutions close monitoring is required in service organizations. In addition, organizational commitment is directly linked to student progression (Raheem, 2009). On the other hand, academic achievement is a much-studied topic that reflects the progression to a specific goal or target (Lüftenegger, et al., 2016). Previous research investigated the influence of departmental commitment on student satisfaction as well as student satisfaction improving their academic performance. As a result, we can assume that departmental dedication and student academic success have a direct relationship.

**H<sub>7</sub>:** *Department commitment has a significant positive impact on student academic performance.*

### 2.2.5 The Moderating Effect of Self-Efficacy

A belief in one's own capacities to execute a certain activity is defined as perceived self-efficacy. It also has an impact on people's attitudes, motives, and behaviors. Aside from that, having experiences is the most operative technique to acquire a strong sentiment of self-efficacy (Bandura, 1994). Individuals with strong self-efficacy set more difficult goals and are driven to attain them. Moreover, self-efficacy influences cognition and behavior as well as has a moderating effect (Hmieleski & Corbett, 2008). Another study demonstrates that academic self-efficacy has a significant influence on students' academic performance (Hayat, Shateri, Amini, & Shokrpour, 2020). In general, we suppose that self-efficacy strengthens the link between student satisfaction and academic achievement.

**H<sub>8</sub>:** *Perceived self-efficacy has a significant positive impact on a student's academic performance.*

**H<sub>9</sub>:** *Perceived self-efficacy moderates the relationship between student satisfaction and academic performance.*

### 3. Methodology

#### 3.1 Data Collection, Sample, and Sampling Technique

In the first phase of the methodology, the questionnaire was developed through an extensive literature review, in-depth interviews, and FGD conducted with academicians and students. The quantitative method has been framed to conduct the study with a structured questionnaire. Moreover, the questionnaires were delivered solely for data collection from the students enrolled in public universities in Bangladesh.

By focusing on simple random sampling, this study's demographic consisted of students from all public universities in Bangladesh. It is recommended that the simple random sampling method is suitable for quantitative statistical analysis and homogeneous populations in nature to avoid any gender bias which ensures an equal chance to be chosen as a sample (Noor, Tajik, & Golzar, 2022). Nevertheless, the total population of this study was 289645 at 47 public universities in Bangladesh (UGC, 2021). The study selected 15 public universities for the demonstrative sample in the study. G\*power was used to calculate the sample size, which had an effect size of 0.19 with a 95% confidence interval and received a total of 490 responses from the selected 15 public universities in Bangladesh (Faul, Erdfelder, Buchner, & Lang, 2009). Power analysis is more accurate to identify the appropriate sample size than to study the entire population (Kang, 2021). As a result, after data cleaning as well as regardless of gender bias, 431 completed responses were used from the total of 490 responses as a sample to conduct the research. The number of samples used is more than five times the total of 44 items (Hair, Risher, Sarstedt, & Ringle, 2019). Table 1 represents the summary of the research design. Moreover, during this study, the author strictly maintained all the ethical principles in terms of respondent autonomy, privacy, and confidentiality. Moreover, permission was obtained from the institutions through its respective department's chairman prior to sending the survey questionnaire. The data collection was conducted from January 2023 to March 2023. They were also invited to actively participate in this study after reading the general purpose and going through some basic ideas about service quality.

**Table 1**

Research Procedure: Methodological Steps - Own Processing

Research Stage	Research Action
Literature Review	Search Engine
	Science Direct and Scopus, Taylor Francis, Emerald, Willey online library, and Google Scholars.
	Key phrases
	Quality dimension, higher education. HESQUEL model
Questionnaire development	Outcomes of the literature review, measurement items, and FGD findings.
Pilot study	The questionnaire was tested on 20 respondents.
Final questionnaire development	Comments and feedback were taken into account to prepare the final questionnaire.
Data Collection	Primary data.
Data Analysis	Microsoft excel, SmartPLS

#### 3.2 Research Instrument

It attempted to develop a questionnaire based on a 5-point Likert Scale to collect data based on respondents' levels of agreement or disagreement with the questionnaire's statements. Responses have been collected both in person and online. All the items were modified and integrated with related content to make them clearer and more intelligible (see Appendix). The questionnaire was completed and returned by 431 of the 450 intended participants, for a response rate of 95.78%.

**Table 2**

Sources of research instruments

Constructs	Items	Sources
Administrative quality	6	(Teeroovengadum, Kamalanabhan, & Seebaluck, 2016)
Transformative quality	5	
Core educational quality	9	
Physical environment quality	7	
Students' satisfaction	3	(Saif, 2014)
Department's commitment	5	(Ardi, Hidayatno, & Yuri M. Zagloel, 2012)
Student academic performance	3	(Mateos, Fernández-Zabala, Palacios, & Díaz-de-Cerio, 2020)
Self-efficacy	5	(Zyl, Klibert, Shankland, See-To, & Rothmann, 2022)

### 4. Analysis & Interpretation

In this study, the total number of respondents was 431. Among them, 41.8% were male students and 58.2 % were female students. The majority of respondents were between the ages of 18 and 25. The dominant age groups are between 19 to 20 (31.3%), and 21 to 22 (27.4%). In the case of respondents' study area, 33.2% were from business and economics, 29.9% were from applied science, and the remaining respondents were from the arts, medicine, and engineering in that order. Besides, most of the students were studying for their bachelor's 1st year and 2nd year (see Table 3).

**Table 3****Descriptive Statistics**

Demographic	Frequency	Percentage (%)	Demographic	Frequency	Percentage (%)
<b>Gender</b>					
Male	180	41.8			
Female	251	58.2			
<b>Age</b>					
<=18	41	9.5	<b>Year/Degree Currently Studying</b>		
19-20	135	31.3	Bachelor 1st Year	33	7.7
21-22	118	27.4	Bachelor 2nd Year	134	31.1
23-24	83	19.3	Bachelor 3rd Year	134	31.1
25=>	54	12.5	Bachelor 4th Year	61	14.2
<b>Area of Study</b>					
Arts	79	18.3	Master's degree	69	16.0
Business and Economics	143	33.2			
Applied Science	129	29.9			
Medical and Engineering	80	18.6			

**4.1 Measurement Model**

To confirm the measurement model, this study assesses two forms of validity suggested by (Ramayah et al., 2017): convergent validity and discriminant validity.

**4.1.1 Convergent Validity**

Convergent validity is typically assessed using loadings, average variance extracted (AVE), and composite reliability (Ramayah et al. 2017). The AVE in this study is greater than the required 0.500, and all loading and composite reliabilities are greater than 0.708 (Ramayah et al. 2017; Hair et al. 2019). Therefore, Table 4 confirms the devouring convergent validity presence. The study also conducted a reliability test using Cronbach alpha and composite reliability. Based on the results of Cronbach alpha, it was found that all the constructs had a score between 0.80 to 0.90 which is sufficient for further analysis (Hair et al. 2019).

**Table 4****Measurement Table**

Construct	Items	Loadings	Cronbach's Alpha	Composite Reliability	Average Variance Extracted (AVE)
Administrative Quality (AQ)	AQ1	0.758	0.887	0.909	0.625
	AQ2	0.818			
	AQ3	0.826			
	AQ4	0.765			
	AQ5	0.734			
	AQ6	0.837			
Core Educational Quality (CEQ)	CEQ1	0.777	0.907	0.924	0.604
	CEQ2	0.768			
	CEQ4	0.785			
	CEQ5	0.784			
	CEQ6	0.766			
	CEQ7	0.758			
	CEQ8	0.752			
	CEQ9	0.824			
	Transformative Quality (TQ)	TQ1			
TQ2		0.910			
TQ3		0.865			
TQ4		0.779			
TQ5		0.813			
Physical Environment Quality (PEQ)	PEQ1	0.719	0.865	0.902	0.649
	PEQ2	0.874			
	PEQ4	0.848			
	PEQ5	0.713			
	PEQ7	0.858			
Students Satisfaction (STS)	STS1	0.876	0.841	0.904	0.759
	STS2	0.858			
	STS3	0.878			
Department's Commitment (DC)	DC1	0.809	0.879	0.911	0.673
	DC2	0.840			
	DC3	0.814			
	DC4	0.808			
	DC5	0.830			
Self-Efficacy (SE)	SE1	0.881	0.889	0.915	0.686
	SE2	0.758			
	SE3	0.716			
	SE4	0.885			
	SE5	0.885			
Perceived Academic Performance (PAP)	PAP1	0.877	0.845	0.907	0.764
	PAP2	0.861			
	PAP3	0.884			

#### 4.1.2 Discriminant Validity

The study used a heterotrait-monotrait (HTMT) correlation ratio to examine the study's discriminant validity. The HTMT is required and the recommended level should be less than 0.85 to consider the constructs as conceptually dissimilar constructs. In our study, we found that all the constructs of our study are less than 0.85 therefore (see Table 5). Thus, we can declare that all the constructs in our study are theoretically different (Hair, Risher, Sarstedt, & Ringle, 2019; Henseler, Ringle, & Sarstedt, 2015; Ramayah, Yeap, Ahmad, Halim, & Rahman, 2017).

**Table 5**  
Heterotrait-Monotrait Ratio (HTMT)

	AQ	CEQ	PEQ	TQ	STS	DC	SE	PAP
AQ								
CEQ	0.150							
PEQ	0.100	0.049						
TQ	0.051	0.169	0.136					
STS	0.069	0.144	0.373	0.257				
DC	0.060	0.172	0.142	0.782	0.313			
SE	0.043	0.047	0.191	0.202	0.165	0.441		
PAP	0.045	0.250	0.164	0.581	0.659	0.565	0.108	

In addition, to avoid serious multicollinearity issues, the VIF of each item in the study should be less than 5. To avoid potential collinearity problems, a VIF value of less than 3 is preferred (Ali, Rasoolimanesh, Sarstedt, Ringle, & Ryu, 2018). The study's items have a VIF that is smaller than the reference value 3, hence there are no obvious or significant multicollinearity problems (see Table 6).

**Table 6**  
VIF

Item	VIF	Item	VIF	Item	VIF	Item	VIF
AQ1	2.256	CEQ6	2.420	PAP2	1.903	SE4	2.482
AQ2	2.050	CEQ7	2.429	PAP3	2.144	SE5	2.792
AQ3	2.106	CEQ8	2.867	PEQ1	1.687	STS1	2.069
AQ4	2.086	CEQ9	2.982	PEQ2	2.218	STS2	1.889
AQ5	2.069	DC1	2.020	PEQ4	2.356	STS3	2.030
AQ6	1.834	DC2	2.330	PEQ5	1.765	TQ1	1.717
CEQ1	2.855	DC3	2.047	PEQ7	2.443	TQ2	3.158
CEQ2	2.775	DC4	2.024	SE1	2.872	TQ3	2.610
CEQ4	2.433	DC5	2.152	SE2	1.883	TQ4	1.835
CEQ5	2.288	PAP1	2.079	SE3	1.850	TQ5	2.151

#### 4.1.3 Inter-correlation analysis

Correlation is a method of statistical analysis used for scientific studies to investigate the strength and direction of the relationship between two or more variables (Lima, Miranda, Vasiljevic, & Baranauskas, 2019). The study explored the inter-correlation matrix among latent variables. Based on the calculations it was found that AQ was positively correlated with DC ( $r = 0.041$ ) and had a negative correlation with CEQ ( $r = -0.126$ ).

Additionally, DC correlated positively with PAP ( $r = 0.488$ ) & TQ ( $r = 0.687$ ). PAP correlated positively to CEQ ( $r = 0.223$ ), STS ( $r = 0.555$ ), & TQ ( $r = 0.504$ ). PEQ, on the other hand, had negative relationships between AQ ( $r = -0.088$ ) & SE ( $r = -0.059$ ). SE correlated negatively with DC ( $r = -0.392$ ) and positively with STS ( $r = 0.335$ ). STS correlated positively with CEQ ( $r = 0.232$ ), PAP ( $r = 0.555$ ), and TQ ( $r = 0.223$ ). Finally, TQ correlated positively with DC ( $r = 0.687$ ), PAP ( $r = 0.504$ ), and STS ( $r = 0.223$ ). The intensities and orientations of these interactions varied and must be assessed in the context of factors under investigation (see Table 7).

**Table 7**  
Inter-correlation analysis

	AQ	CEQ	DC	PAP	PEQ	SE	STS	TQ
AQ	1.000	-0.126	0.041	0.027	-0.088	0.003	0.065	0.013
CEQ	-0.126	1.000	0.157	0.223	0.015	-0.033	0.132	0.156
DC	0.041	0.157	1.000	0.488	-0.059	-0.392	0.270	0.687
PAP	0.027	0.223	0.488	1.000	0.153	-0.104	0.555	0.504
PEQ	-0.088	0.015	-0.059	0.153	1.000	0.142	0.335	0.130
SE	0.003	-0.033	-0.392	-0.104	0.142	1.000	-0.153	-0.170
STS	0.065	0.132	0.270	0.555	0.335	-0.153	1.000	0.223
TQ	0.013	0.156	0.687	0.504	0.130	-0.170	0.223	1.000

4.2 Structural Model (Hypothesis Testing)

To evaluate the structural model, examine the R2, beta ( $\beta$ ), and t-values using a bootstrapping approach with a sample size of 5000 (Hair, Hult, Ringle, & Sarstedt, 2017).

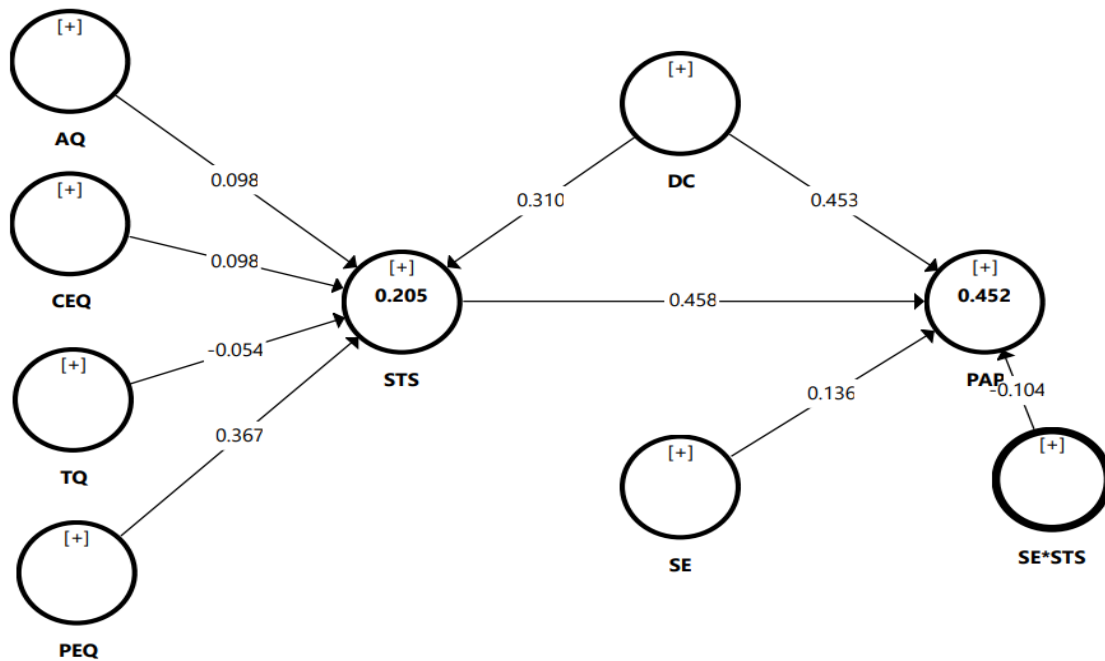

**Fig. 2.** Structural equation model

**Table 8**  
Hypothesis Testing

Path	Beta	Standard Error	t Statistics	p Values	Confidence Interval		Results
					5.00%	95.00%	
H1 AQ → STS	0.098	0.063	1.556	0.060	-0.120	0.146	Not accepted
H2 CEQ → STS	0.098	0.043	2.277	0.011	0.021	0.155	Accepted
H3 TQ → STS	-0.054	0.065	0.835	0.202	-0.158	0.050	Not accepted
H4 PEQ → STS	0.367	0.044	8.363	0.000	0.293	0.437	Accepted
H5 DC → STS	0.310	0.066	4.724	0.000	0.209	0.417	Accepted
H6 DC → PAP	0.453	0.059	7.658	0.000	0.358	0.553	Accepted
H7 STS → PAP	0.458	0.045	10.120	0.000	0.384	0.535	Accepted
H8 SE → PAP	0.136	0.046	2.936	0.002	0.078	0.226	Accepted
H9 SE*STS → PAP	-0.104	0.046	2.267	0.012	-0.176	-0.028	Not accepted

Legend: AQ- Administrative Quality; CEQ- Core Educational Quality; TQ- Transformative Quality; PEQ- Physical Environmental Quality; DC- Department's Commitment; PAP- Perceived Academic Performance; STS- Student's Satisfaction; SE- Self Efficacy.

In the model above, the path coefficient is represented by the value of the outer model, and the value R2 is indicated in the inner circle of the constructs (see Figure 2). According to the value of R square, the independent, mediating, and moderating



factors can clarify the variance of the dependent variables students' satisfaction and academic performance by 20.5% and 45.2%, respectively.

The hypotheses were tested using 5000 bootstrapping samples (Hair, Risher, Sarstedt, & Ringle, 2019). Because the hypotheses were found to be unidirectional, the bootstrapping was done with a one-tailed t-test based on previous work. The present study finds that administrative quality and transformative quality do have not any significant influence on student satisfaction. On the other hand, core educational quality and student satisfaction have a positive influence ( $\beta = 0.098$ ,  $t = 2.277$ ,  $p\text{-value} < 0.01$ ), physical environmental quality and department's commitments highly influenced students' satisfaction ( $\beta = 0.367$ ,  $t = 8.363$ ,  $p\text{-value} < 0.01$ ), ( $\beta = 0.310$ ,  $t = 4.724$ ,  $p\text{-value} < 0.01$ ) respectively. Moreover, the department's commitment ( $\beta = 0.453$ ,  $t = 7.658$ ,  $p\text{-value} < 0.01$ ), students' satisfaction ( $\beta = 0.458$ ,  $t = 10.120$ ,  $p\text{-value} < 0.01$ ), and self-efficacy ( $\beta = 0.136$ ,  $t = 2.936$ ,  $p\text{-value} < 0.01$ ) lead students perceived academic performance. Notwithstanding the study didn't find any moderating effect of self-efficacy between students' satisfaction and perceived academic performance. The findings, on the other hand, accepted hypotheses H2, H4, H5, H6, H7, and H8 while rejecting hypotheses H1, H3, and H9.

## 5. Discussion

The educational environment is getting competitive and requires dynamism alike the other sectors in the present era. The study's findings can be used to guide institutions, both public and private, in developing quality-focused visions and missions. The previous HESQUAL model did not address whether department engagement could be another predictor of student satisfaction. The goal of this research was to determine the influence of service quality on student satisfaction and perceived academic performance through the mediating role of departments' commitment. Model testing verifies our work using confirmatory factor analysis and structural equation modeling. As a result, with the exception of the direct relationship between H1 and H3, most of the assumptions provided in our model are accepted where students are not influenced by administrative quality and transformative quality. Therefore, the study didn't find the moderating effect of self-efficacy.

Moreover, the study found that students focused on core educational qualities like teaching materials, up-to-date theoretical and practical knowledge from the teachers, etc. This matched well with (Ali, Shah, & Mangi, 2019) findings. We also revealed that students need some physical environmental facilities like a canteen, libraries, and recreational opportunities to be satisfied (Ali, Shah, & Mangi, 2019). On the other hand, the department's commitments also needed to support their academic activities to both increase their satisfaction and academic performance (Ardi, Hidayatno, & Yuri M. Zagloel, 2012; Lüftenegger, et al., 2016). The university management which is responsible for creating a culture prone to the responsive, communicative, and interactive environment of teaching, learning, and assessment areas, can benefit from the findings of the study as a whole. Overall, this satisfaction and resilience lead to improved academic performance (Ahmed, et al., 2010; Sharabati, Alhileh, & Abusaimah, 2019).

### 5.1 Implications

#### 5.1.1 Theoretical implication

The educational environment is getting competitive and requires dynamism alike the other sectors in the present era. The contribution can be generated by providing an in-depth understanding of the study framework which illustrates the relationship among the variables. This study revealed the extended and modified model of HESQUAL and confirmed that students' basic satisfaction depends on only core educational quality, and physical environment quality. With the extended one the departments' commitment is also considered an important factor in both their satisfaction and academic performance. Besides, it can be understood that students' efficacy influences academic performance but does not strengthen the relationship between student satisfaction and academic performance.

#### 5.1.2 Practical implication

The study's findings can be used to guide institutions in developing quality-focused visions and missions. The university management which is responsible for creating a culture prone to a responsive, communicative, and interactive environment in teaching, learning, and assessment areas, can benefit from the study's findings as a whole. The service quality dimensions which have been addressed in this study can be the strong determinants for student satisfaction, henceforth, the university administration can emphasize the performance of these dimensions, to attain higher student satisfaction which ultimately leads to higher performance. In relation to this, the study can bring fruitful contributions to policymakers by providing a framework to evaluate the service dimensions. Application of the HESQUAL model can improve service quality which leads to higher student satisfaction and substantially increase academic excellence.

## 5.2 Limitations and Future Directions

The nature of the sample was relatively homogeneous as most of the respondents are from business schools, which might bias the perception. Public universities have been chosen as study frameworks that might differ from private universities. In addition, this study didn't consider some control variables like gender and age. Further studies are endorsed to be carried out with the same framework in other areas such as private universities, primary education, and other service sectors, as well as consider the control variables. A different framework can be proposed by introducing some other variables such as student motivation, university branding, stakeholder satisfaction, and personalities which will certainly broaden the scope. Other stakeholders such as teachers, staff, parents, potential employers, and government bodies can be taken into consideration to address the issue and a comparative study can be drawn. Cross-comparison with other developing countries can be initiated as the extension of this study. This model can be extended, tailored, or modified by aligning the requirements of stakeholders, culture, sub-culture, students' needs, and so on. Direction to future researchers can be observed in the extended area of service dimension shaping student satisfaction, motivation, and student intelligence.

## 6. Ethical Issues

After receiving approval from the department chairman of each university, the questionnaire was distributed. Respondents were asked to voluntarily participate in the survey after reading the general objectives of this study. In addition, some basic concepts were given for better understanding through conditioning without revealing the names of the respondents and institutions. Moreover, this study is reviewed and approved by the Biosafety, Biosecurity, and Ethical committee of Jahangirnagar University and the reference number is BBEC, JU/M 2024/02 (83).

## 7. Conclusion

Quality education aligned with student satisfaction is the ultimate goal for higher education. Student learning, which results from academic performance, would improve through quality services. Apart from the academic knowledge leadership skills with a multi-faceted personality, communication, and interpersonal proficiency, confidence at a high level, being updated with advanced technology, and having good knowledge of the industry climate, are the new requirements of this highly competitive and unpredictable business world. The findings of this study shed light on the importance of forming a strategy aligned with a student focus, selecting faculty members not only with a good academic background but with pertinent experience, highly committed and dedicated, learning environment with opportunities for academic growth and personality development, supportive staff with continuous training, effective communication at every level, providing campus facilities which increase the standard of life, buildings aligned with proper educational support, building mental health with indoor theatre, gymnasium, swimming pool, playfields, cafeteria with the catering of nutritious food.

## References

- Abbas, J. (2020). HEISQUAL: A modern approach to measure service quality in higher education institutions. *Studies in Educational Evaluation*, 67, 100933. doi:<https://doi.org/10.1016/j.stueduc.2020.100933>
- Afthanorhan, A., Zainudin Awang, N. R., Foziah, H., & Liza, P. (2019). Assessing the effects of service quality on customer satisfaction. *Management Science Letters*, 9(11), 13–24. doi:10.5267/j.msl.2018.11.004
- Ahmed, I., Nawaz, M. M., Ahmad, Z., Ahmad, Z., Shaukat, M. Z., Usman, A., . . . Ahmed, N. (2010). Does service quality affect students' performance? Evidence from institutes of higher learning. *African journal of business management*, 4(12), 2527.
- Akareem, H. S., & Hossain, S. S. (2016). Determinants of education quality: what makes students' perception different? *Open review of educational research*, 3(1), 52-67. doi:<https://doi.org/10.1080/23265507.2016.1155167>
- Alathathi, N. (2012). Obstacles to the application of total quality management in higher education institutions in the Kingdom of Saudi Arabia. *Arab Journal for Quality Assurance I Higher Education*, 5(9), 66 – 99.
- Alauddin, M., Ahsan, S. M., Kamal, M. A., Alam, M. M., & Hassan, A. (2020). The assessment of perceived service quality dimensions of hotel industry in Bangladesh. *Journal of multidisciplinary academic tourism*, 5(2), 105-114. doi:<https://doi.org/10.1108/QAE-06-2014-0028>
- Aldaibat, A. (2018). Obstacles to the implementation of quality management at the Jordanian private universities. *Journal of ALnajah University*, 32(11), 1077 – 2004.
- Alhazmi, N. (2017). Impact of total quality management on marketing of tourism services: An applied study on hotels located in Al-Kharj City in K.S.A. *International Journal of Management and Economics Invention*, 4(1), 1595-1605.
- Ali, D. B., Shah, D. N., & Mangi, S. (2019). Determining the impact of service quality on students' satisfaction in public sector universities of Thailand: An empirical approach. *sia Pacific-Annual Research Journal of Far East & South East Asia*, 35, 70-88.

- Ali, F., Rasoolimanesh, S. M., Sarstedt, M., Ringle, C., & Ryu, K. (2018). An assessment of the use of partial least squares structural equation modeling (PLS-SEM) in hospitality research. *International Journal of Contemporary Hospitality Management*, 30, 514-538. doi:<https://doi.org/10.1108/IJCHM-10-2016-0568>
- Al-Mansour, & H., A. (2007). *Application of TQM to Financial Services*. Retrieved from <http://faculty.kfupm.edu.sa/CEM/bushait/cem515/term-papers/TQM-Finance.pdf>
- Alves, H., & Raposo, M. (2010). The influence of university image on student behaviour. *International journal of educational management*, 24(1), 73-85.
- Angur, G., M., Natarajan, Jahera, R. & S., J. (1999). Service Quality in the Banking Industry: An Assessment in a Developing Economy. *International Journal of Bank Marketing*, 17, 116-23.
- Anis, A., & Abdullah, Z. (2014). Defining quality education in higher learning institutions: Divergent views of stakeholders. *International Journal of Arts & Sciences*, 7(1), 375.
- Ardi, R., Hidayatno, A., & Yuri M. Zagloel, T. (2012). Investigating relationships among quality dimensions in higher education. *Quality assurance in education*, 20(4), 408-428. doi:<https://doi.org/10.1108/09684881211264028>
- Azam, A. (2018). Service Quality Dimensions and Students' Satisfaction: A study of Saudi Arabian Private Higher Education Institutions. *European Online Journal of Natural and Social Sciences*, 7(2), 275-284.
- Bandura, A. (1994). *Self-efficacy*. In V. S. Ramachandran (Ed.) (Vol. 4). New York: New York: Academic Press.
- Beer, M. (2003). Why total quality management programs do not persist: The role of management quality and implications for leading a TQM transformation. *Decision Sciences*, 34, 623-642. doi: <https://doi.org/10.5167/uzh-150640>
- Bose, R. (2002). Customer Relationship Management: Key Components for IT Success. *Industrial Management & Data Systems*, 102(2), 89-97. doi:<https://doi.org/10.1108/02635570210419636>
- Brooks, R., Gupta, A., Jayadeva, S., & Abrahams, J. (2021). Students' views about the purpose of higher education: a comparative analysis of six European countries. *Higher Education Research & Development*, 40(7), 1375-1388. doi:<https://doi.org/10.1080/07294360.2020.1830039>
- Cahyono, Y., Purwanto, A., Sukanta, Azizah, F. N., Fitriaty, Wijoyo, H., . . . Sugianto, A. (2020). Impact of Service Quality, University Image and Students Satisfaction Towards Student Loyalty: Evidence From Indonesian Private Universities. *Journal of Critical Reviews*, 7(19), 3916-3924 .
- Calabrese, A. & (2015). Design and blueprinting for total quality management implementation in service organisations. *Total Quality Management and Business Excellence*, 26(7-8), 719-732.
- Carraher, S. M., Franklin, G. M., Parnell, B. A., & Sullivan, S. E. (2006). Entrepreneurial Service Performance and Technology Management: A Study of China and Japan. *Journal of Technology Management in China*, 1(1). doi:<https://doi.org/10.1108/17468770610642786>
- Catalin, S. H., Bogdan, B., & Dimitrie, G. R. (2014). The Existing Barriers In Implementing Total Quality Management. *Annals of Faculty of Economics*, 1(1), 1234-1240.
- Chen, Y. C., & Tam, W. M. (1997). Multi-models of quality in education. *Quality assurance in Education*, 22-31.
- Cheng, Y. i., & Tam, W. M. (1997). Multi-models of quality in education. *Quality assurance in Education*, 5(1), 22-31. doi:<https://doi.org/10.1108/09684889710156558>
- Clemes, M. D., Cohen, D. A., & Wang, Y. (2013). Understanding Chinese university students' experiences: An empirical analysis. *Asia Pacific Journal of Marketing and Logistics*, 25(3), 391-427.
- Cooper, D. R., & Schindler, P. S. (2003). *Business Research Methods*. New York: McGraw-Hill.
- Crosby, P. B. (1979). *Quality is Free: The Art of Making Quality Certain*, New American Library, New York. NY: Penguin.
- Dehghan, A., Dugger, J., Dobrzykowski, D., & Balazs, A. (2014). The antecedents of student loyalty in online programs. *International journal of educational management*.
- Dhaqane, M. K., & Afrah, N. A. (2016). Satisfaction of Students and Academic Performance in Benadir University . *Journal of Education and Practice*, 7(24), 59-63.
- Dhawan, S. (2022). Higher Education Quality and Student Satisfaction: Meta-Analysis, Subgroup Analysis and Meta-Regression. *Metamorphosis*, 21(1), 48-66. doi:<https://doi.org/10.1177/09726225221082376>
- Doménech-Betoret, F., Abellán-Roselló, L., & Gómez-Artiga, A. (2017). Self-Efficacy, Satisfaction, and Academic Achievement: The Mediator Role of Students' Expectancy-Value Beliefs. *Frontiers in psychology*, 8, 1193. doi:<https://doi.org/10.3389/fpsyg.2017.01193>
- Dwaikat, N. Y. (2021). A comprehensive model for assessing the quality in higher education institutions. *The TQM Journal*, 33(4), 841-855. doi:<https://doi.org/10.1108/TQM-06-2020-0133>
- Eisenberger, R., Huntington, R., Hutchison, S., & Sowa, D. (1986). Perceived organizational support. *Journal of Applied psychology*, 71(3), 500-507. doi:<https://psycnet.apa.org/doi/10.1037/0021-9010.71.3.500>
- Elango, Gudep, R. & K., V. (2006). A Comparative Study on the Service Quality and Customers Satisfaction among Private, Public and Foreign Banks. *The ICFAI Journal of Management*, 5(3), 8-19.
- Fan, J., & Prasongsukarn, K. (2019). Investigating the Effects Amongst Quality Dimensions in Higher Education. RSU International Research Conference. Retrieved from <https://rsucon.rsu.ac.th/proceedings>
- Faul, F., Erdfelder, E., Buchner, A., & Lang, A.-G. (2009). Statistical power analyses using G\* Power 3.1: Tests for correlation and regression analyses. *Behavior research methods*, 41(4), 1149-1160. doi:<https://doi.org/10.3758/BRM.41.4.1149>
- Feigenbaum, A. (1951). *Quality control: Principles, practice and administration: An industrial management tool for improving product quality and design and for reducing operating costs and losses*. McGraw-Hill.

- Gao, H. L. (2020). Understanding the Impact of Administrative Service Quality on Satisfaction and Loyalty Towards University Students. *Higher Education Research*, 5(1), 25-30. doi:10.11648/j.her.20200501.15
- Granovetter, M. (1985). Economic Action and Social Structure: The Problem of Embeddedness. *The sociology of economic life*, 22-45.
- Grönroos, C. (2006). Adopting a service logic for marketing. *Marketing theory*, 6(3), 317-333. doi:https://doi.org/10.1177/1470593106066794
- GS, S., R, C., RN, A., & TJ, K. (2002). Management's perception of total quality service in the banking sector of developing economy- a critical analysis. *International Journal of Bank Marketing*, 20, 181-196.
- Hair, J. F., Hult, G. T., Ringle, C. M., & Sarstedt, M. (2017). *A primer on partial least squares structural equation modeling (PLS-SEM)*. Thousand Oaks: Sage.
- Hair, J. F., Risher, J. J., Sarstedt, M., & Ringle, C. M. (2019). When to use and how to report the results of PLS-SEM. *European Business Review*, 1, 31. doi:http://dx.doi.org/10.1108/EBR-11-2018-0203
- Han, H., Kiatkawsin, K., & Kim, W. (2018). Physical classroom environment and student satisfaction with courses. *Assessment & Evaluation in Higher Education*, 43(1), 110-125. doi:https://doi.org/10.1080/02602938.2017.1299855
- Hassan, M. A. (2012). An Empirical Assessment of Service Quality and its Relationship with Customer loyalty, Evidence From the Telecom Sector of Pakistan. *International Journal of Asian Social Sciences*, 2(6).
- Hayat, A. A., Shateri, K., Amini, M., & Shokrpour, N. (2020). Relationships between academic self-efficacy, learning-related emotions, and metacognitive learning strategies with academic performance in medical students: a structural equation model. *BMC medical education*, 20(1), 1-11. doi:https://doi.org/10.1186/s12909-020-01995-9
- Hasseler, J., Ringle, C. M., & Sarstedt, M. (2015). A new criterion for assessing discriminant validity in variance-based structural equation modeling. *Journal of the academy of marketing science*, 43, 115-135. doi:https://doi.org/10.1007/s11747-014-0403-8
- Hmieleski, K. M., & Corbett, A. C. (2008). The contrasting interaction effects of improvisational behavior with entrepreneurial self-efficacy on new venture performance and entrepreneur work satisfaction. *Journal of business venturing*, 23(4), 482-496. doi:https://doi.org/10.1016/j.jbusvent.2007.04.002
- Hosen, M., Uddin, M. N., Hossain, S., Islam, M. A., & Ahmad, A. (2022). The impact of COVID-19 on tertiary educational institutions and students in Bangladesh. *Heliyon*, 8(1), 1-9. doi:https://doi.org/10.1016/j.heliyon.2022.e08806
- Hossain, M. A., Hossain, M. M., & Chowdhury, T. H. (2018). An empirical investigation from graduates' perspective. *International journal of quality & reliability management*, 35(1), 145-162. doi:https://doi.org/10.1108/IJQRM-02-2015-0031
- Jasti, N. V., Venkateswaran, V., & Kota, S. (2021). Total Quality Management in higher education: a literature review on barriers, customers and accreditation. *The TQM Journal*, 34(5), 1250-1272. doi:https://doi.org/10.1108/TQM-11-2020-0256
- Juran, J., & Gryna, F. (1988). *Juran's Quality Control Handbook* (4th ed.). New York: McGraw-Hill: McGraw-Hill.
- Juran, J., & Gryna, F. (1993). *Quality Planning and Analysis*. New York: McGraw Hill, Inc.
- Kang, H. (2021). Sample size determination and power analysis using the G\*Power software. *Journal of educational evaluation for health professions*, 18. doi:https://doi.org/10.3352/jeehp.2021.18.17
- Khalifa, G. S., Binnawas, M. S., Alareef, N. A., Alkathiri, M. S., Alsaadi, T. A., Alneadi, K. M., & Alkhater, A. (2021). The Role of Holistic Approach Service Quality on Student's Behavioural Intentions: The Mediating Role of Happiness and Satisfaction. *City University eJournal of Academic Research*, 3(1), 12-32.
- Kothari, C. R. (2004). *Research Methodology: Methods and Techniques*, (Second Edition). *BARRIERS TO TOTAL QUALITY MANAGEMENT (TQM) IMPLEMENTATION IN THE MAURITIAN FOOD INDUSTRY* (pp. 611-616). UK: New Age International Publisher.
- Krücken, G. (2021). Multiple competitions in higher education: a conceptual approach. *Innovation*, 23(2), 163-181. doi:https://doi.org/10.1080/14479338.2019.1684652
- Lee, H., Lee, Y., & Yoo, D. (2000). The determinants of perceived service quality and its relationship with satisfaction. *Journal of services marketing*, 14(3), 217-231. doi:https://doi.org/10.1108/08876040010327220
- Lehdonvirta, V., Oksanen, A., Räsänen, P., & Blank, G. (2021). Social media, web, and panel surveys: using non-probability samples in social and policy research. *Policy & internet*, 13(1), 134-155. doi:https://doi.org/10.1002/poi3.238
- Lima, F. M., Miranda, L. C., Vasiljevic, G., & Baranauskas, M. C. (2019). An intra and inter-conferences correlation analysis of the field of HCI: revealing new trends from the international and brazilian communities. (pp. 1-11). In Proceedings of the 18th Brazilian Symposium on Human Factors in Computing Systems.
- Liu, Y., Bao, T., Zhao, D., Sang, H., & Fu, B. (2022). Evaluation of Student-Perceived Service Quality in Higher Education for Sustainable Development: A Fuzzy TODIM-ERA Method. *Sustainability*, 14, 4761. doi:https://doi.org/10.3390/su14084761
- Lüftenegger, M., Klug, J., Harrer, K., Langer, M., Spiel, C., & Schober, B. (2016). Students' achievement goals, learning-related emotions and academic achievement. *Frontiers in psychology*, 7, 603. doi:https://doi.org/10.3389/fpsyg.2016.00603
- Lynch, D., Gottfried, M., Green, W., & Thomas, C. A. (2023). Using Economics to Illuminate the Dynamic Higher Education Landscape. *Strategic Management Journal*, 44(2), 520-548. doi:https://doi.org/10.1002/smj.3444
- Malhotra, N. K. (2006). *Marketing research: an application orientation*.

- Mark, E. (2013). Student satisfaction and the customer focus in higher education. *Journal of higher education policy and management*, 35(1), 2-10. doi:<https://doi.org/10.1080/1360080X.2012.727703>
- Martirosyan, N. M., Saxon, D. P., & Wanjohi, R. (2014). Student Satisfaction and Academic Performance in Armenian Higher Education. *American International Journal of Contemporary Research*, 4(2), 1-5.
- Mateos, N. E., Fernández-Zabala, A., Palacios, E. G., & Díaz-de-Cerio, I. I.-d.-l.-F. (2020). School Climate and Perceived Academic Performance: Direct or Resilience-Mediated Relationship? *Sustainability*, 13(1), 68. doi:<https://doi.org/10.3390/su13010068>
- Mercredi, P. I. (2021, March 10). *The influence of the physical environment on student satisfaction*. Université du Luxembourg. Retrieved January 25, 2023, from [https://www.fr.uni.lu/layout/set/print/fhse/actualites/the\\_influence\\_of\\_the\\_physical\\_environment\\_on\\_student\\_satisfaction](https://www.fr.uni.lu/layout/set/print/fhse/actualites/the_influence_of_the_physical_environment_on_student_satisfaction)
- Mosadeghrad, A. M. (2014). Why TQM programmes fail? A pathology approach The TQM Journal. *Emerald Group Publishing Limited*, 26(2), 160-187. doi:<https://doi.org/10.1108/TQM-12-2010-0041>
- Muhibbullah, M., Mamun, A. A., & Afroz, R. (2021). Quality of Higher Education: Improving the Well-being through Humanizing Digital Entrepreneurship Program. *Journal of Asian Finance, Economics and Business*, 8(2), 1201–1213. doi:<https://doi.org/10.13106/jafeb.2021.vol8.no2.1201>
- Naidu, L. (2021). *Service quality of administrative staff for student satisfaction a KZN University of Technology (Doctoral dissertation)*.
- Nguyen, T.-T., Pham, H.-H., Cao, Q.-T., Nguyen, X. A., & Do, M. T. (2021). Investigating the impacts of core educational quality on the satisfaction and loyalty of parents of secondary school students: The mediating role of transformative quality. *Cogent Education*, 8(1), 1-20. doi:<https://doi.org/10.1080/2331186X.2021.1911283>
- Noor, S., Tajik, O., & Golzar, J. (2022). Simple Random Sampling. *International Journal of Education & Language Studies*, 1(2), 78-82. doi:<https://doi.org/10.22034/ijels.2022.162982>
- Nwabueze, U. (2001). An industry betrayed: The case of total quality management in manufacturing. *TQM Magazine*, 13, 400-408.
- Parasuraman, A., Zeithaml, V. A., & Berry, L. L. (1985). A Conceptual Model of Service Quality and Its Implications for Future Research. *Journal of marketing*, 49(4), 41-50. doi:<https://doi.org/10.1177/002224298504900403>
- Parasuraman, A., Zeithaml, V. A., & Berry, L. L. (1988). SERVQUAL Instrument. *Journal of retailing*. doi:<https://psycnet.apa.org/doi/10.1037/t09264-000>
- Peters, T. J., & Robert H. Waterman, J. (1982). *In Search of Excellence*. New York: Harper and Row.
- Rabbania, G., & Chowdhury, S. (2014). Quality of Higher Education in Bangladesh: Governance Framework and Quality Issues. *Beikent University Journal of Social Sciences- BUJSS*, 7(1), 78-91. doi:<https://doi.org/10.18221/bujss.86058>
- Raheem, A. S. (2009). *The level of commitment and its relation to Students' Achievement as perceived by English Language teachers in Public Schools in Tulkarm District*. Nablus: An-Najah National University. Retrieved from <https://hdl.handle.net/20.500.11888/7234>
- Ramayah, T., Yeap, J. A., Ahmad, N. H., Halim, H. A., & Rahman, S. A. (2017). Testing a Confirmatory model of Facebook Usage in SmartPLS using Consistent PLS. *International Journal of Business and Innovation*, 3(2), 1-14.
- Rozak, L. A., Arifin, M. B., Rykova, I. N., Grishina, O. A., Komariah, A., Nurdin, D., . . . Dudnik, O. V. (2022). Empirical Evaluation of Educational Service Quality in the Current Higher Education System. *Emerging Science Journal*, 6. doi:<http://dx.doi.org/10.28991/ESJ-2022-SIED-05>
- Saif, N. I. (2014). The Effect of Service Quality on Student Satisfaction: A Field Study for Health Services Administration Students. *International Journal of Humanities and Social Science*, 4(8), 172-181.
- Sebastianelli, R. &. (2003). Understanding the obstacles to TQM success. *The Quality Management Journal*, 10(3), 45–56.
- Senthilkumar, N., & Arulraj, A. (2011). SQM-HEI—determination of service quality measurement of higher education in India. *Journal of Modelling in Management*, 6(1), 60-78. doi: 10.1108/1746566111112502
- Sharabati, A.-A. A., Alhileh, M. M., & Abusaimh, H. (2019). Effect of service quality on graduates' satisfaction. *Quality Assurance in Education*. doi:10.1108/QAE-04-2018-0035
- Sharif, I. M. (2005). *The Barriers Affecting the Implementation of Quality Management System-ISO 9000 in Libyan Manufacturing Public Sector Organisations*. University of Salford, UK.
- Singh, S., & Jasial, S. S. (2021). Moderating effect of perceived trust on service quality – student satisfaction relationship: evidence from Indian higher management education institutions. *Journal of Marketing for Higher Education*, 31(2), 280-304. doi:<https://doi.org/10.1080/08841241.2020.1825029>
- Subair, S. S., & Talabi, R. B. (2015). Teacher Shortage in Nigerian Schools: Causes, Effects and Administrators Coping Strategies. *Asia Pacific Journal of Education, Arts and Sciences*, 2(4), 31-37.
- Sultan, P., & Wong, H. Y. (2011). Service quality in a higher education context: antecedents and dimensions. *International Review of Business Research Papers*, 7(2), 11-20.
- Sumaedi, S., Bakti, G. M., & Metasari, N. (2012). An empirical study of state university students' perceived service quality. *Quality assurance in Education*, 20(2), 164-183. doi:<https://doi.org/10.1108/09684881211219424>
- Talib, F. R. (2011). Prioritising the practices of total quality management: an analytic hierarchy process (AHP) analysis for the service industries. *Total Quality Management and Business Excellence*, 22(12), 1331-1351.
- Talib, F., & Rahman, Z. (2015). Identification and prioritization of barriers to total quality management implementation in service industry. *The TQM Journal*, 27(5), 591 - 615. doi:<http://dx.doi.org/10.1108/TQM-11-2013-0122>

- Talib, F., Rahman, Z., & MN, Q. (2012). Journal of Telecommunications System & Management Impact of Total Quality Management and Service Quality in the Banking Sector. *International Journal of Ethics in Social Sciences*, 2(1), 2308-5096.
- Teeroovengadam, V., Kamalanabhan, T. J., & Seebaluck, A. K. (2016). Measuring service quality in higher education: Development of a hierarchical model (HESQUAL). *Quality Assurance in Education*, 24(2), 244-258. doi:https://doi.org/10.1108/QAE-06-2014-0028
- Teo, T. D. (2006). Towards a holistic perspective of customer relationship management, No. CRM) implementation: A case study of the Housing and Development Board, Singapore. *Decision Support Systems*, 42(3), 1613-1627.
- Tor, D. (2015). *Exploring physical environment as hidden curriculum in higher education: A grounded theory study*. Dumlupinar Bulvar: OpenMETU.
- Ugboro, I. O. (2000). Top management leadership, employee empowerment, job satisfaction, and customer satisfaction in TQM organizations: An empirical study. *Journal of Quality Management*, 5, 247-272.
- UGC. (2021). *48th Annual Report*. UGC. Retrieved from <http://www.ugc.gov.bd/>
- Umbach, P. D., & Porter, S. R. (2002). How do academic departments impact student satisfaction? Understanding the contextual effects of departments. *Research in higher education*, 43, 209-234. doi:https://doi.org/10.1023/A:1014471708162
- Venkateshwarlu, N., Agarwal, A., & Kulshreshtha, M. (2011). Implementation of TQM: A Case Study in an Auto Company. *Asia-Pacific Business Review*, VII(2), 74-82.
- Venkatraman, S. (2007). A framework for implementing TQM in higher education programs. *Quality Assurance in Education*, 15(1), 92-112.
- Weerasinghe, I., & Fernando, R. (2018). Critical factors affecting students' satisfaction with higher education in Sri Lanka. *Quality Assurance in Education*, 26(1), 115-130. doi:http://dx.doi.org/10.1108/QAE-04-2017-0014
- York, T. T., Gibson, C., & Rankin, S. (2015). Defining and measuring academic success. *Practical assessment, research, and evaluation*, 1(5), 20. doi:https://doi.org/10.7275/hz5x-tx03
- Zeithaml, V. A., Berry, L. L., & Parasuraman. (1988). Communication and Control Processes in the Delivery of Service Quality. *Journal of marketing*, 52(2), 35-48. doi:https://doi.org/10.1177/002224298805200203
- Zhao, F. (2003). Enhancing the quality of online higher education through measurement. *Quality Assurance in education*, 11(4), 241-221.
- Zyl, L. E., Klibert, J., Shankland, R., See-To, E. W., & Rothmann, S. (2022). The General Academic Self-Efficacy Scale: Psychometric Properties, Longitudinal Invariance, and Criterion Validity. *ournal of Psychoeducational Assessment*, 40(6), 777-789. doi:https://doi.org/10.1177/07342829221097174

## Appendix A

### Questionnaire

Constructs	Modified and integrated items	Sources
<b>Administrative quality</b>	AQ1 Staffs' willingness to help students. AQ2 Staffs' ability to solve students' problems. AQ3 Politeness of administrative staff. AQ4 Level of bureaucracy and useless difficulties. AQ5 Service delivery time. AQ6 Well-defined official procedures and regulations.	(Teeroovengadam, Kamalanabhan, & Seebaluck, 2016)
<b>Transformative quality</b>	TQ1 My university promotes self-confidence among students. TQ2 Facilitates the development of students' problem-solving skills. TQ3 Promotes self-awareness. TQ4 Promotes innovative thinking. TQ5 Helps to enrich academic knowledge and skills.	
<b>Core educational quality</b>	CEQ1 Teachers' ability to understand students' needs. CEQ2 Teachers' effort to meet students' interest. CEQ3 Availability of teachers to guide and advise students. CEQ4 Clearly defined course content and course objectives. CEQ4 Challenging academic standards to ensure students. overall development. CEQ5 Relevance of course content to the future/current job of students. CEQ6 Usage of multimedia in teaching. CEQ7 Well-designed examinations and continuous assessment. CEQ8 Theoretical knowledge, qualifications, and practical knowledge of teachers. CEQ9 Lecturers being up to date in their area of expertise.	
<b>Physical environment quality</b>	PEQ1 Classroom availability. PEQ2 Safety on campus. PEQ3 Appearance of buildings and grounds. PEQ4 Adequate cafeteria infrastructure. PEQ5 Adequate library infrastructure. PEQ6 Adequate sports and recreational infrastructure. PEQ7 Adequate IT facilities, photocopy and printing facilities, and transport facilities.	
<b>Students' satisfaction</b>	STS1 Your trust in the services provided by the university. STS2 Your degree of satisfaction with university learning services. STS3 Your recommendation to others whether to attend the university.	(Saif, 2014)
<b>Department's commitment</b>	DC1 Our department is committed to quality improvement. DC2 Our department is committed to infrastructure development. DC3 Our department is committed to supporting students' extracurricular activities. DC4 Our department is committed to supporting student's academic activities. DC5 Our department is committed to career counseling activities	(Ardi, Hidayatno, & Yuri M. Zagloel, 2012)
<b>Perceived academic performance</b>	PAP1 I think I'm a good student. PAP2 I enjoy doing my academic work. PAP3 I get good grades.	(Mateos, Fernández-Zabala, Palacios, & Díaz-de-Cerio, 2020)
<b>Self-efficacy</b>	SE1 I generally manage to solve difficult academic problems if I try hard enough. SE2 I know I can stick to my aims and accomplish my goals in my field of study. SE3 I will remain calm in my exam because I know I will have the knowledge to solve the problems. SE4 I know I can pass the exam if I put in enough work during the semester. SE5 The motto 'if other people can, I can too' applies to me when it comes to my field of study.	(Zyl, Klibert, Shankland, See-To, & Rothmann, 2022)



© 2025 by the authors; licensee Growing Science, Canada. This is an open access article distributed under the terms and conditions of the Creative Commons Attribution (CC-BY) license (<http://creativecommons.org/licenses/by/4.0/>).