

## Beyond the swipe: Understanding the power of TikTok marketing-interaction, entertainment, and trendiness in shaping purchase intentions

Yunita Wijaya Handranata<sup>a</sup>, Maria Grace Herlina<sup>b\*</sup>, Leticia Soendoro<sup>a</sup> and Qori Kamiliya<sup>a</sup>

<sup>a</sup>Business Creation Program, BINUS Business School Undergraduate Program, Bina Nusantara University, Jakarta, Indonesia 11480

<sup>b</sup>Management Department, BINUS Business School Undergraduate Program, Bina Nusantara University, Jakarta, Indonesia 11480

### CHRONICLE

#### Article history:

Received: January 18, 2024

Received in revised format: February 20, 2024

Accepted: May 8, 2024

Available online: May 8, 2024

#### Keywords:

TikTok

Social media

Purchase intention

Brand engagement

Consumer behavior

### ABSTRACT

This study investigates the relationship between interaction, entertainment, trendiness, brand engagement, and purchase intention in the context of TikTok as a social media platform. Using a quantitative research approach, online questionnaires were distributed to 197 respondents who met specific criteria, including active usage of TikTok and being under 45 years old. The data collection period spanned from March 2023 to May 2023. Data analysis was conducted using variance-based structural equation modeling (PLS-SEM 4.0). The independent variables in the study are interaction (X1), entertainment (X2), and trendiness (X3), with brand engagement (Z) serving as the mediator variable and purchase intention (Y) as the dependent variable. The results revealed that interaction, entertainment, and trendiness significantly positively affect purchase intention, with brand engagement playing a moderating role in this relationship. This study sheds light on the influence of TikTok content attributes on consumers' purchase intention and underscores the importance of brand engagement as a key factor in shaping their purchasing decisions.

© 2024 by the authors; licensee Growing Science, Canada.

## 1. Introduction

Social media has become a cornerstone of modern communication, creativity, and social interaction (Onuorah et al., 2022). In Indonesia, internet penetration has soared to an impressive 78.19 per cent as of 2023, encompassing around 215.6 million individuals out of a total population of 275.8 million (Yati, 2023). Moreover, the number of active social media users in Indonesia has surged to 60.4% of the population, roughly equivalent to 167 million people (Kemp, 2023). With this surge in social media users, businesses increasingly recognise the importance of utilising these platforms to engage with customers and foster brand growth (Constantinides, 2009; Shofiya & Fachira, 2021).

Consumers' purchase intentions are significantly influenced by their experiences on social media platforms, including establishing emotional connections with brands, which can play a pivotal role in persuading customers to make purchases (Toor et al., 2017). Engaging content on social media can cultivate positive brand perceptions and encourage ongoing interactions with the brand (Osei-Frimpong & McLean, 2018). Furthermore, the accessibility of product information on social media platforms profoundly shapes consumer behaviour during the purchasing journey (Ebrahimi et al., 2022).

Despite extensive research on the role of interaction, entertainment, and trendiness in shaping purchase intentions through social media, limited attention has been given to TikTok as a viable marketing and sales platform despite its widespread usage. Additionally, prior studies have yielded inconsistent results, highlighting the need for further analysis to explore the factors

\* Corresponding author.

E-mail address [herlina01@binus.edu](mailto:herlina01@binus.edu) (M. G. Herlina)

ISSN 2561-8156 (Online) - ISSN 2561-8148 (Print)

© 2024 by the authors; licensee Growing Science, Canada.

doi: 10.5267/j.ijds.2024.5.006

influencing customer purchase intentions and to strengthen evidence supporting the relationships posited in each hypothesis. Therefore, this study aims to address these research gaps and illuminate the factors influencing consumer purchase intentions within the realm of marketing activities, providing valuable insights for businesses looking to refine their social media marketing strategies.

## 2. Literature review

### 2.1 Interaction

Social interaction on social media platforms entails users' ability to form relationships and express opinions to other users (Choi et al., 2016). Interactive social media use presents an opportunity for brands to enhance communication with customers, fostering a positive brand perception (Ismail, 2017). The capacity to upload engaging content that promotes interaction is pivotal in cultivating positive brand-customer communication (Wang et al., 2019). Consequently, heightened interaction levels correlate with increased customer engagement, evident in actions like liking, commenting, and sharing content with peers (Cheung, Pires, & Rosenberger, 2020). Positive responses garnered from active customer participation can prompt constructive feedback, aiding in product quality improvement (Merrilees, 2016). Moreover, engaged customers are more inclined to collaborate with companies in generating new ideas and innovations. From these findings, the following hypothesis can be proposed:

**H<sub>1</sub>:** *Interaction influences brand engagement.*

### 2.2 Entertainment

Entertainment serves as a fundamental need for individuals, offering an escape and emotional transition, as well as aesthetic enjoyment (Harshini, 2015). In the realm of social media marketing, entertainment plays a pivotal role in fostering customer growth alongside a brand (Kujur & Singh, 2017). Companies aiming to boost brand engagement often leverage entertaining content across their social media platforms, inviting customers to partake in various experiences (Ashley & Tuten, 2015). Additionally, when brands successfully publish posts that spark discussion among customers, they foster deeper involvement with the brand, thereby enhancing brand awareness within the broader community and shaping its image (Kujur & Singh, 2017). Entertaining brand posts serve as a catalyst for motivating the company's social media followers to actively participate, satisfying their consumption needs for entertainment content (Harshini, 2015). Research indicates that the majority of customers respond more positively to entertaining brand posts, contributing to heightened brand popularity (De Vries et al., 2012). Based on these insights, it can be hypothesized that:

**H<sub>2</sub>:** *Entertainment influences brand engagement.*

### 2.3 Trendiness

Currently, social media platforms are used to disseminate circulate new information, encompassing surveillance, knowledge dissemination, pre-purchase information, and inspiration (Algharabat, 2017). They signify a brand's capacity to deliver the latest information within a defined timeframe (Naaman et al., 2013). In the digital age, social media platforms serve as hubs for accessing up-to-the-minute news and trends, aiding individuals in expanding their knowledge base. Consequently, social media has evolved into a primary platform for individuals seeking information on the latest products. The presence of social media mitigates information delays in product purchases, empowering customers to interact and delve into product details more comprehensively (Khan et al., 2019). The objective behind disseminating the latest information is to foster customer involvement in company development and elevate brand and product awareness. Successful brand establishment can elevate a brand's reputation, positioning its products as superior offerings, thereby prompting customers to actively seek and regularly check social media for brand-related updates (Cheung, Pires, & Rosenberger, 2020). Based on these insights, it can be hypothesized that:

**H<sub>3</sub>:** *Trendiness influences brand engagement.*

### 2.4 Brand Engagement

Kuvykaite & Piligrimiene (2014) define brand engagement as the extent to which consumers perceive themselves as involved with a brand's social media contacts. Engagement between customers and brands can offer excellent opportunities for companies to achieve their business goals, and if managed professionally, can foster emotional bonds that endure over time (Barhemmati & Ahmad, 2015). These bonds indirectly assist in persuading customers to purchase the offered products, making customer engagement a primary concern for business professionals (Toor et al., 2017). In other words, the likelihood of a customer's purchase intention for a product increases if the experience during the purchase process is positive (Bilal et al., 2021). Factors that can influence customer engagement with a brand include the ability of the brand to fulfill desired wants, needs, and prices (Abrar, 2018). Strong brand engagement leads to sustained membership, the creation of new prospects

through customer recommendations, and purchase intentions (Lee et al., 2020). This theory is supported by the role of customer decisions in purchases, which heavily depend on product value and recommendations from other customers through social media (Dehghani & Tumer, 2015).

**H4:** *Brand engagement influences purchase intention.*

The research framework is presented in Fig.1.

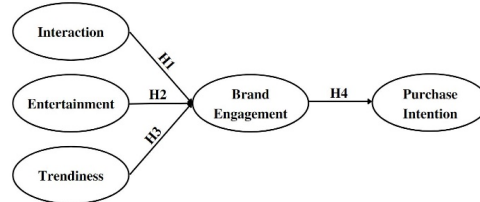

**Fig. 1.** Research Framework

**3. Research Methodology**

The data collection method utilized in this study involved administering a questionnaire to evaluate each variable using an ordinal scale with five response options. The questionnaire items were derived from previous scholarly works. Specifically, interaction (IN) and entertainment (EN) were adapted from (Cheung, Pires, & Rosenberger, 2020), while trendiness (TS) was adopted from Cheung, Pires, & Rosenberger (2020) and Seo & Park (2018). Brand engagement (BE) drew from Choedon & Lee (2020), Cheung, Pires, Rosenberger, et al. (2020), and Shofiya & Fachira (2021); and purchase intention (PI) was adopted from Toor et al. (2017) and Alalwan (2018). The sample population consisted of 196 respondents who met specific criteria, namely being under 45 years old and actively purchasing products through social media. According to Structural Equation Modeling (SEM) principles, the recommended sample size for SEM analysis ranges from 100 to 200 respondents or 5 to 10 times the number of indicators (Kurniawan & Puspitaningtyas, 2016). Therefore, given that this study comprises 18 indicators, a minimum of 180 respondents is required (18 indicators × 10 respondents). The collected questionnaire data will be processed using SmartPLS 4.0 software.

**4. Findings and Discussion**

This research was conducted on a national scale and did not focus on a specific region in Indonesia. However, most of the respondents were gathered from the island of Java due to the rising trend of online purchases and the proximity to shop domiciles. The research was initiated in March 2023 and concluded in May 2023.

*4.1 Respondent Profile*

The demographic profile of the respondents is presented in Table 1. Of the total respondents, 35% were male and 65% were female. In terms of age distribution, 3% of respondents were under 15 years old, 46% were aged between 15 and 25 years, 36% were aged between 26 and 35 years, and 15% were aged between 36 and 45 years.

**Table 1**  
Socio-Demographic Profile

Respondent Characteristic	Total	
	Number	%
Gender	Male	68 / 35
	Female	128 / 65
Age (years)	< 15	7 / 3
	15 – 25	90 / 46
	26 – 35	70 / 36
	36 – 45	29 / 15

*4.2 Measurement Model Analysis*

In testing validity and reliability, this research utilized the SmartPLS 4.0 software application. According to Rainy & Arisena (2020), for convergent validity, indicators with outer loadings above 0.7 are considered valid. Additionally, in the convergent validity test based on the Extracted Average Variance (AVE) value, variables with an AVE value above 0.5 are considered valid. Moreover, Firohmatillah and Arisena (2020) suggest that for reliability tests based on composite reliability, a value

above 0.6 indicates that the variable is reliable. Similarly, for reliability testing based on Cronbach's alpha, a value above 0.6 indicates that the variable is reliable.

**Table 2**

Measurement model analysis

Latent Variable	Indicator	Loading Factor (>0.7)	Cronbach's Alpha (>0.6)	Composite Reliability (≥0.6)	Remark	AVE (≥0.5)	Remark
Interaction	IN1	0.807	0.808	0.874	Reliable	0.635	Valid
	IN2	0.838			Reliable		
	IN3	0.757			Reliable		
	IN4	0.783			Reliable		
Entertainment	EN1	0.818	0.786	0.875	Reliable	0.701	Valid
	EN2	0.896			Reliable		
	EN3	0.795			Reliable		
Trendiness	TS1	0.842	0.800	0.802	Reliable	0.714	Valid
	TS2	0.843			Reliable		
	TS3	0.850			Reliable		
Brand Engagement	BE1	0.716	0.811	0.867	Reliable	0.566	Valid
	BE2	0.724			Reliable		
	BE3	0.738			Reliable		
	BE4	0.785			Reliable		
	BE5	0.794			Reliable		
Purchase Intention	PI1	0.893	0.848	0.908	Reliable	0.766	Valid
	PI2	0.879			Reliable		
	PI3	0.855			Reliable		

Table 2 indicates that all indicators have loading factor values above 0.7, confirming their validity. Additionally, the AVE value for each variable is above 0.5, further supporting their validity. Moreover, the reliability analysis based on composite reliability demonstrates that all variables have values above 0.6, indicating their reliability. This finding is consistent with the reliability analysis based on Cronbach's alpha, where all variables have values above 0.6, confirming their reliability. Therefore, it can be concluded that all variables are deemed valid and reliable.

#### 4.3 Structural Model Analysis

According to Artanto et al. (2021), the R-Square value can be categorized as high if it reaches 0.75, moderate if it reaches 0.5, and low if it reaches 0.25. In this study, the level of influence of the moderating variable is 0.624, while the dependent variable is 0.364 (as shown in Table 3). The independent variables, namely interaction, entertainment, and trendiness, collectively account for 62.4% of the variance in the formation of brand engagement, indicating a moderate level of influence. The remaining 37.6% variance is attributed to other unexplored factors not considered in this study.

**Table 3**

R-Square Analysis

Variable	R-square
Brand Engagement	0.624
Purchase Intention	0.364

On the other hand, the moderating variable, brand engagement, explains 36.4% of the variance in purchase intention, also indicating a moderate level of influence. The remaining 63.6% variance is attributed to other unexplored factors not considered in this study.

## 5. Hypothesis Testing

According to Artanto et al. (2021), a path coefficient with a positive value indicates a positive relationship, while a negative value indicates a negative relationship. Additionally, according to Hair Jr et al. (2021), a t-statistic value above 1.96 is considered valid, and a p-value below 0.05 is considered valid. Table 4 presents the results of hypothesis testing.

**Table 4**

Hypothesis Testing Results

Hypotheses	Path Coefficient	T-statistic	P-values	Results
IN → BE	0.334	3.637	0.000	H1 Accepted
EN → BE	0.204	2.164	0.031	H2 Accepted
TS → BE	0.336	4.270	0.000	H3 Accepted
BE → PI	0.604	8.387	0.000	H4 Accepted

Note: IN: Interaction, EN: Entertainment, TS: Trendiness, BE: Brand Engagement, PI: Purchase Intention.

Based on the research findings, it is demonstrated that the t-statistic value obtained from the first hypothesis, which examines the relationship between the interaction variable and brand engagement, is 3.637. This value exceeds 1.96, indicating a significant influence of the interaction variable on brand engagement. This finding aligns with research by Bilal et al. (2021), Choedon and Lee (2020), Estefania and Yuwono (2023), and Liu et al. (2021). Properly established interactions between sellers and buyers can foster emotional attachments, leading buyers to remain engaged with the brand. Moreover, buyers feel valued when their interactions with sellers and other buyers are appreciated by the brand. Furthermore, it is demonstrated that the t-statistic value obtained from the second hypothesis, regarding the relationship between the entertainment variable and brand engagement, is 2.164. This value surpasses 1.96, indicating a significant influence of the entertainment variable on brand engagement. This finding is consistent with research by Bilal et al. (2021), Cheung, Pires, & Rosenberger (2020), Liu et al. (2021), Onuorah et al. (2022), and Shofiya and Fachira (2021). Today's social media users have a high demand for entertaining content to unwind, take breaks from busy activities, or simply refresh their minds.

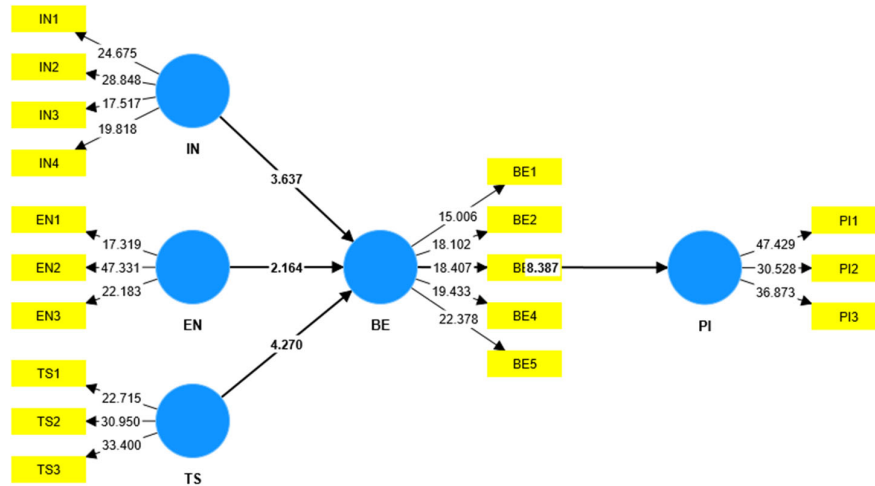

**Fig. 3.** Path analysis of structural model (bootstrapping)

Similarly, it is demonstrated that the t-statistic value obtained from the third hypothesis, examining the relationship between the trendiness variable and brand engagement, is 4.270. This value exceeds 1.96, indicating a significant influence of the trendiness variable on brand engagement. This finding is consistent with research by Bilal et al. (2021), Estefania & Yuwono (2023), Liu et al. (2021), Onuorah et al. (2022), and Shofiya & Fachira (2021). Social media serves as a platform not only for entertainment but also for obtaining the latest information, including product trends, thereby enriching users' knowledge. Likewise, in the fourth hypothesis, it is demonstrated that the t-statistic value between brand engagement variables and purchase intention is 8.387. This value exceeds 1.96, indicating a significant influence of the brand engagement variable on purchase intention. This finding is consistent with research by Bilal et al. (2021), Choedon & Lee (2020), Estefania & Yuwono (2023), Shofiya & Fachira (2021), and Toor et al. (2017). The presence of interaction, entertainment, and trendiness that foster brand attachment indirectly persuades buyers to purchase the products offered. Buyers are more inclined to make purchases when all their needs are met, such as responsive and engaging sellers, captivating and up-to-date content, and products that are in line with current trends.

## 6. Conclusions

Based on the research findings, it can be concluded that interaction, entertainment, and trendiness significantly and positively influence purchase intention, moderated by brand engagement. This research underscores the importance of fostering good interaction between sellers and buyers to enhance brand engagement. Additionally, uploading content that provides entertainment and aligns with current trends can also contribute to increased brand engagement. By establishing a favorable product image, emotional connections with the brand can be formed, ultimately influencing one's decision to purchase a product.

### 6.1 Theoretical Implication

With this research, empirical evidence is provided regarding the relationship between variables that are still under debate. Researchers aim to contribute to knowledge in the field and provide insights for enhancing purchase intention by focusing on the factors influencing it. The key influencing factors identified are interaction, entertainment, and trendiness, moderated by brand engagement. This study underscores the importance of these factors in shaping consumer behavior and decision-making processes related to product purchases.

## 6.2 Managerial Implication

Currently, online purchasing has become a prevalent practice among consumers, leading many sellers to conduct marketing and sales activities through online channels, including social media. However, findings from previous research in this area remain contentious. Thus, the results of this study can provide valuable insights for enhancing purchase intention, particularly for food and beverage products. Businesses must prioritize their marketing efforts on social media platforms, ensuring they engage with their audience effectively. For instance, uploading entertaining content can prevent customers from becoming bored and encourage them to explore other shared content. Additionally, it's crucial for businesses to stay updated with the latest product information and promotions, ensuring customers feel informed and engaged in the business's development. Moreover, fostering good interaction between buyers and sellers is essential in increasing purchase intention. Businesses should focus on building meaningful connections with their customers through responsive and engaging interactions. By paying attention to these factors, businesses can effectively leverage social media to enhance purchase intention and drive sales of food and beverage products.

## 7. Limitation and Further Research

This research has several limitations. Firstly, the sample size utilized in the study may not be sufficiently large to capture a comprehensive understanding of the phenomenon under investigation. Therefore, future research endeavors are encouraged to employ larger sample sizes to enhance the generalizability of the findings.

Secondly, this research solely focuses on examining the impact of interaction, entertainment, and trendiness on purchase intention. Other potentially influential factors, such as live streaming, which enables direct interaction between customers and sellers, have not been explored. Therefore, future studies could delve into investigating these additional factors to provide a more comprehensive understanding of purchase intention in the context of online marketing.

Furthermore, the geographical scope of this research is limited to Indonesia. Conducting similar studies in other countries can offer insights into potential cultural or contextual differences in consumer behavior and purchase intention. Hence, future research endeavors are suggested to explore this phenomenon in diverse cultural and geographical contexts to enrich the understanding of purchase intention in online marketing settings.

## References

- Abrar, K. (2018). Impact of Augmented Reality on Consumer Purchase Intention with the Mediating role of Customer Brand Engagement. *Bahria University Journal Of Management & Technology*, 2(1), 64–80. <https://www.bjmt.bahria.edu.pk/index.php/ojs/article/view/20>
- Alalwan, A. A. (2018). Investigating the impact of social media advertising features on customer purchase intention. *International Journal of Information Management*, 42(June), 65–77. <https://doi.org/10.1016/j.ijinfomgt.2018.06.001>
- Algharabat, R. S. (2017). Kybernetes Article information :Linking social media marketing activities with brand love The mediating role of self-expressive brands. *Marketing*, 46(10), 1801–1819. <https://doi.org/10.1108/K-04-2017-0130>
- Artanto, F. A., Fahlevi, R., & Rachmayani, N. A. (2021). Partial Least Square-Structural Equation Modeling (PLS-SEM) Pada Hubungan Kepuasan Konsumen Terhadap Produk (Studi Kasus Perkumpulan Penggiat Programmer Indonesia). *Surya Informatika*, VOL 11 NO.(SSN: 2477-3042), 4045.
- Ashley, C., & Tuten, T. (2015). Creative strategies in social media marketing: An exploratory study of branded social content and consumer engagement. *Psychology & Marketing*, 32(1), 15–27. <https://doi.org/10.1002/mar>
- Barhemmati, N., & Ahmad, A. (2015). Effects of Social Network Marketing (SNM) on Consumer Purchase Behavior through Customer Engagement. *Journal of Advanced Management Science*, 3(4), 307–311. <https://doi.org/10.12720/joams.3.4.307-311>
- Bilal, M., Jianqu, Z., & Ming, J. (2021). How Consumer Brand Engagement Effect on Purchase Intention? The Role of Social Media Elements. *Journal of Business Strategy Finance and Management*, 2(1), 44–55. <https://doi.org/10.12944/jbsfm.02.01.06>
- Cheung, M. L., Pires, G., & Rosenberger, P. J. (2020). The influence of perceived social media marketing elements on consumer–brand engagement and brand knowledge. *Asia Pacific Journal of Marketing and Logistics*, 32(3), 695–720. <https://doi.org/10.1108/APJML-04-2019-0262>
- Cheung, M. L., Pires, G., Rosenberger, P. J., & De Oliveira, M. J. (2020). Driving consumer–brand engagement and co-creation by brand interactivity. *Marketing Intelligence and Planning*, 38(4), 523–541. <https://doi.org/10.1108/MIP-12-2018-0587>
- Choedon, T., & Lee, Y. (2020). The Effect of Social Media Marketing Activities on Purchase Intention with Brand Equity and Social Brand Engagement: Empirical Evidence from Korean Cosmetic Firms. *Knowledge Management in Modern Organizations*, 21(3), 141–160. <https://doi.org/10.4018/978-1-59904-261-9.ch004>
- Choi, E. K. (Cindy), Fowler, D., Goh, B., & Yuan, J. (Jessica). (2016). Social Media Marketing: Applying the Uses and Gratifications Theory in the Hotel Industry. *Journal of Hospitality Marketing and Management*, 25(7), 771–796. <https://doi.org/10.1080/19368623.2016.1100102>

- Constantinides, E. (2009). Social Media / Web 2.0 as Marketing Parameter: An Introduction. *Proceedings of 8th International Congress Marketing Trends*, 15–17.
- De Vries, L., Gensler, S., & LeeFlang, P. S. H. (2012). Popularity of Brand Posts on Brand Fan Pages: An Investigation of the Effects of Social Media Marketing. *Journal of Interactive Marketing*, 26(2), 83–91. <https://doi.org/10.1016/j.intmar.2012.01.003>
- Dehghani, M., & Tumer, M. (2015). A research on effectiveness of Facebook advertising on enhancing purchase intention of consumers. *Computers in Human Behavior*, 49, 597–600. <https://doi.org/10.1016/j.chb.2015.03.051>
- Ebrahimi, P., Basirat, M., Yousefi, A., Nekmahmud, M., Gholampour, A., & Fekete-farkas, M. (2022). Social Networks Marketing and Consumer Purchase Behavior: The Combination of SEM and Unsupervised Machine Learning Approaches. *Big Data and Cognitive Computing*, 6(2). <https://doi.org/10.3390/bdcc6020035>
- Estefania, E., & Yuwono, W. (2023). Peran Media Sosial Terhadap Consumer Brand Engagement pada Purchase Intention Smartphone di Kota Batam. *Journal of Economic, Management, Accounting and Technology*, 6(1), 103–114. <https://ojs.unsiq.ac.id/index.php/jematech/article/view/3930>
- Firohmatillah, A. R., & Arisena, A. (2020). Pengaruh Stress Kerja dan Kepuasan Kerja terhadap Turnover Intention Pada Koperasi X di Jawa Barat Menggunakan Pendekatan Partial Least Square (PLS). *Jurnal Co Management*, 3(2), 508–517. <https://doi.org/10.32670/comanagement.v3i2.429>
- Hair Jr, J. F., Hult, G. T. M., Ringle, C. M., Sarstedt, M., Danks, N. P., & Ray, S. (2021). Review of Partial Least Squares Structural Equation Modeling (PLS-SEM) Using R: A Workbook. In *Springer Nature*. <https://doi.org/10.1080/10705511.2022.2108813>
- Harshini, C. S. (2015). Influence of social media ads on consumer's purchase intention. *International Journal of Current Engineering and Scientific Research*, 2(10), 110–115.
- Ismail, A. R. (2017). The influence of perceived social media marketing activities on brand loyalty: The mediation effect of brand and value consciousness. *Asia Pacific Journal of Marketing and Logistics*, 29(1), 129–144. <https://doi.org/10.1108/APJML-10-2015-0154>
- Kemp, S. (2023). *DIGITAL 2023: INDONESIA*. Datareportal. <https://datareportal.com/reports/digital-2023-indonesia>
- Khan, Z., Yang, Y., Shafi, M., & Yang, R. (2019). Role of social media marketing activities (SMMAs) in apparel brands customer response: A moderated mediation analysis. *Sustainability (Switzerland)*, 11(19), 15–17. <https://doi.org/10.3390/su11195167>
- Kujur, F., & Singh, S. (2017). Engaging customers through online participation in social networking sites. *Asia Pacific Management Review*, 22(1), 16–24. <https://doi.org/10.1016/j.apmr.2016.10.006>
- Kurniawan, B., & Puspitaningtyas, Z. (2012). (2016). *Metode Penelitian Kuantitatif*.
- Kuvykaite, R., & Piligrimiene, Z. (2014). Consumer Engagement into Brand Equity Creation. *Procedia - Social and Behavioral Sciences*, 156(April), 479–483. <https://doi.org/10.1016/j.sbspro.2014.11.225>
- Lee, J. K., Hansen, S. S., & Lee, S. Y. (2020). The effect of brand personality self-congruity on brand engagement and purchase intention: The moderating role of self-esteem in Facebook. *Current Psychology*, 39(6), 2116–2128. <https://doi.org/10.1007/s12144-018-9898-3>
- Liu, X., Shin, H., & Burns, A. C. (2021). Examining the impact of luxury brand's social media marketing on customer engagement: Using big data analytics and natural language processing. *Journal of Business Research*, 125(April), 815–826. <https://doi.org/10.1016/j.jbusres.2019.04.042>
- Merrilees, B. (2016). Journal of Product & Brand Management. *Marketing Intelligence & Planning*, 25(5), 402–408. <https://doi.org/10.1108/EUM0000000001126>
- Naaman, M., Becker, H., & Gravano, L. (2013). Hip andTrendy: Characterizing EmergingTrends onTwitter. *Journal of the American Society for Information Science and Technology*, 64(July), 1852–1863. <https://doi.org/10.1002/asi>
- Onuorah, C. P., Ojiaku, O. C., & Olise, M. C. (2022). Effect of Social Media Marketing on Customer Brand Engagement in the Banking Industry: Evidence From an Emerging Economy. *Management & Marketing*, 20(2), 125–140. <https://doi.org/10.52846/mnmk.20.2.01>
- Osei-Frimpong, K., & McLean, G. (2018). Examining online social brand engagement: A social presence theory perspective. *Technological Forecasting and Social Change*, 128(March 2017), 10–21. <https://doi.org/10.1016/j.techfore.2017.10.010>
- Seo, E. J., & Park, J. W. (2018). A study on the effects of social media marketing activities on brand equity and customer response in the airline industry. *Journal of Air Transport Management*, 66(September 2017), 36–41. <https://doi.org/10.1016/j.jairtraman.2017.09.014>
- Shofiya, N. A., & Fachira, I. (2021). Effects of Social Media Marketing Towards Probiotic Chicken Customers' Purchase Intention: Customer Engagement as a Mediator. *Malaysian Journal of Social Sciences and Humanities (MJSSH)*, 6(8), 518–531. <https://doi.org/10.47405/mjssh.v6i8.943>
- Toor, A., Husnain, M., & Hussain, T. (2017). The impact of e-payment service quality on consumer action in Pakistan: Intentions as a mediator. *Asian Journal of Business and Accounting*, 10(1), 167–199.
- Wang, Y., Ahmed, S. C., Deng, S., & Wang, H. (2019). Success of social media marketing efforts in retaining sustainable online consumers: An empirical analysis on the online fashion retail market. *Sustainability (Switzerland)*, 11(13). <https://doi.org/10.3390/su11133596>
- Yati, R. (2023). *Survei APJII: Pengguna Internet di Indonesia Tembus 215 Juta Orang*. Bisnis Tekno. <https://teknologi.bisnis.com/read/20230308/101/1635219/survei-apjii-pengguna-internet-di-indonesia-tembus-215-juta-orang>



© 2024 by the authors; licensee Growing Science, Canada. This is an open access article distributed under the terms and conditions of the Creative Commons Attribution (CC-BY) license (<http://creativecommons.org/licenses/by/4.0/>).