

Review of synthesis process of 1,3,4-oxadiazole analogs

Assiya Atif^{a*}, Abouelhaoul El Alami^a, Fatima Youssoufi^a, Said Jebbari^a and Houssine Ait Sir^a

^a*Bioorganic Chemistry Team, Faculty of Science, Chouaib Doukkali University, El jadida, Morocco*

CHRONICLE

Article history:

Received August 3, 2024

Received in revised form

September 16, 2024

Accepted November 5, 2024

Available online

November 5, 2024

Keywords:

1,3,4-oxadiazole

Synthesis

ABSTRACT

This review presents 1,3,4-oxadiazole which has considerable importance in the fields of pharmacy, medicine, corrosion and coordinate chemistry. 1,3,4-oxadiazole plays a vital role and is a simple substance for many pharmacokinetic compounds such as antifungal drugs, antibacterial drugs, most cancer tumors and anti-inflammatory drugs. This study describes many methods for the synthesis of 1,3,4-oxadiazole.

© 2025 by the authors; licensee Growing Science, Canada.

1. Introduction

Heterocycle chemistry is a very broad field. Heterocycles are cyclic organic molecules containing at least one non-carbon atom, such as nitrogen or oxygen, which are attracting attention because of their wide range of pharmacological actions¹. Heterocycles constitute the largest classical division of organic chemistry and are of immense importance in both the biological and industrial fields, the majority of biologically active pharmaceuticals and agrochemicals being heterocycles. In this group, a key role plays nitrogen containing, five-membered heterocycles such as piroles, pyrazolines, azoles, oxazoles, oxadiazoles and other²⁻⁷. Oxadiazole is of considerable interest in chemistry, an interest clearly demonstrated by the fact that, in recent years, the number of patent applications containing oxadiazole rings has increased significantly (100%). 1,3,4-oxadiazole is an aromatic heterocyclic compound containing one oxygen and two nitrogen atoms in a five-membered ring⁸. 1,3,4-oxadiazole is an aromatic heterocyclic compound containing one oxygen and two nitrogen atoms in a five-membered ring⁹.

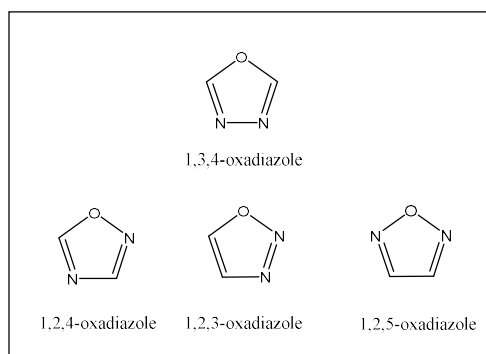

Fig. 1. General structure of 1,3,4-oxadiazole and isomers.

* Corresponding author
E-mail address assia.atif@gmail.com (A. Atif)

There are three other known isomers for 1,3,4-oxadiazole, namely 1,2,4-oxadiazole, 1,2,3-oxadiazole and 1,2,5-oxadiazole. While the 1,2,5-oxadiazole isomer is significantly less reported¹⁰, the 1,2,3-oxadiazole rings are rather unstable and these compounds are generally observed in their tautomeric diazoketone form and are relatively complicated to synthesize¹¹. However, 1,3,4-oxadiazole and 1,2,4-oxadiazole are better known and more widely studied by researchers¹².

In the context of drug discovery and development, a number of 1,3,4-oxadiazole-containing compounds are commercially available, including ataluren (A) for the treatment of cystic fibrosis¹³, furamizole (B) which has antibacterial activity¹⁴ and doxazosin (C) which possesses the 1,3,4-oxadiazole ring is widely used as an antihypertensive drug¹⁵.

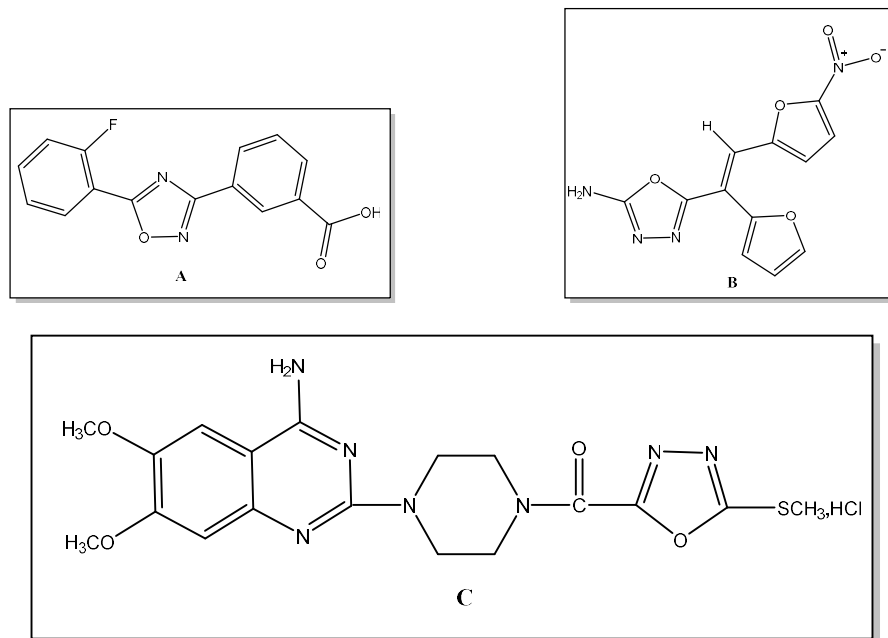
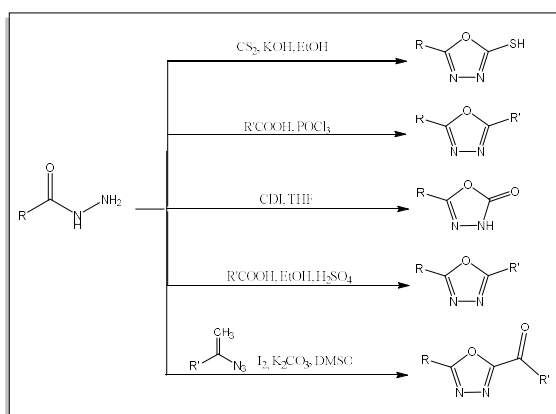
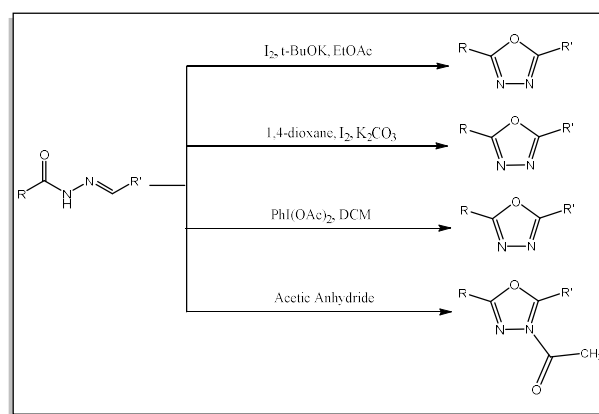

Fig. 2. (A) Ataluren, (B) Furamizole, (C) Doxazosine levulinate

1,3,4-oxadiazole has various biological activities such as: antifungal^{16,17}, antiproliferative¹⁸, anticancer¹⁹, antibacterial²⁰, analgesic²¹, anticonvulsant²², antihypertensive²³ and anti-inflammatory^{24,25}, some oxadiazole analogs are used as muscle relaxants²⁶, tranquilizers²⁷, cathepsin K15 inhibitors²⁸, angiogenesis inhibitors, HIV integrase inhibitors²⁹ and tyrosinase inhibitors³⁰. Other studies have revealed that heterocyclic compounds containing one or more N, O and S atoms can affect corrosion inhibition in acidic aqueous solutions and metals³¹⁻³⁷, for which 1,3,4-oxadiazole analogs are the best corrosion inhibitors³⁸, and that they have been able to synthesize metal complexes and polymers with different applications in several fields in recent years^{39,40}. Given the richness of 1,3,4-oxadiazole chemistry and the diversity of their applications, we present in this review the important and recent synthetic processes in the synthesis of 1,3,4-oxadiazole analogs reported in the literature.



Scheme 1. Methods for the synthesis of 1,3,4-oxadiazole analogues from hydrazide derivatives.



Scheme 2. Methods for the synthesis of 1,3,4-oxadiazole analogues from acylhydrazone derivatives.

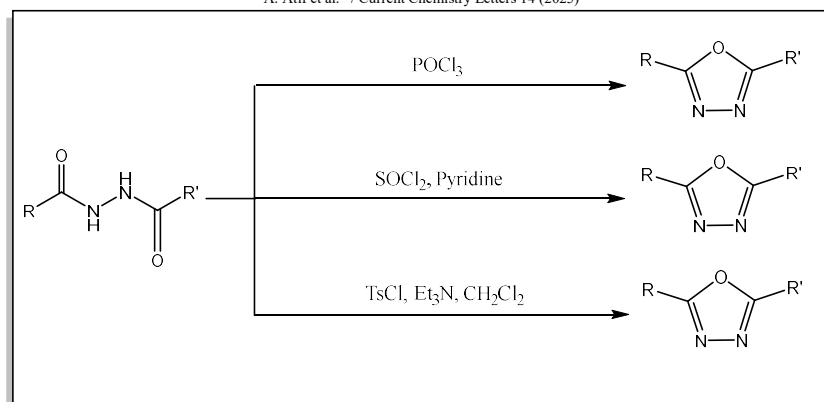

Scheme 3. Methods for the synthesis of 1,3,4-oxadiazole analogues from acylhydrazine derivatives.

2. Preparation approaches of 1,3,4- oxadiazole analogs

Nasir Rasool et al.⁴¹ synthesized 5-(1-(4-isobutylphenyl)ethyl)-1,3,4-oxadiazole-2-thiol. First, a mixture of ethanol, 2-(4-isobutylphenyl)propanoic acid and concentrated H_2SO_4 was heated at reflux to give **2** as a pale yellow oily liquid in 90% yield and with a melting point at 263-265 °C. Next, 2-(4-isobutylphenyl)propanehydrazide was produced by dissolving methyl 2-(4-isobutylphenyl)propanoate **2** in methanol (MeOH) with the addition of hydrazine hydrate at reflux at 90-100 °C to give **3** as a white crystalline solid in 88% yield and melting at 77-78 °C. Finally, 2-(4-isobutylphenyl)propanehydrazide **3** was dissolved in ethanol, KOH and CS_2 were also added during the reaction. The mixture was heated to reflux at 95 °C to give 5-(1-(4-isobutylphenyl)ethyl)-1,3,4-oxadiazole-2-thiol as an off-white crystalline solid in 84% yield, with a melting point of 115-118 °C. This method is a key for the synthesis of compounds that have significant results ($P < 0.05$) in terms of seizure severity of mice at 6 Hz (32 mA) and PTZ (80 mg/kg), protection and mortality as well as significant results of PTZ tests.

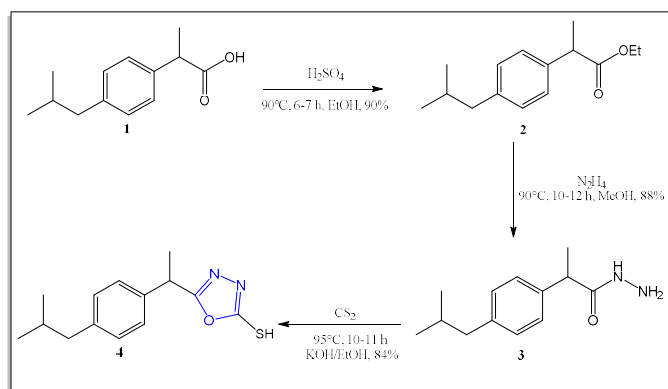

Scheme 4. Synthesis of 1,3,4-oxadiazole analogs by Nasir Rasool et al.

Hala E.M. Tolan et al.⁴² prepared 1,3,4-oxadiazole analogs, firstly 2,5-dioxo-5-phenylpentanoic acid **5** was dissolved in ethanol and a few drops of H_2SO_4 at reflux to give white ethyl 2,5-dioxo-5-phenylpentanoate **6** in 90% yield. Next, a solution of ethyl 2,5-dioxo-5-phenylpentanoate **6** in ethanol and hydrazine hydrate was heated at reflux to form pale yellow 2,5-dioxo-5-phenylpentanehydrazide **7** in 78% yield, with a melting point of 123-125 °C. Then, to a solution of 2,5-dioxo-5-phenylpentanehydrazide **7** in ethanol, a solution of potassium hydroxide in water and carbon disulfide was added. The reaction mixture was heated under reflux to give yellow potassium salt **8** in 86% yield, with a melting point of 265-267 °C. Finally, 1-phenyl-4-(5-thioxo-4,5-dihydro-1,3,4-oxadiazol-2-yl)butane-1,4-dione was obtained by reacting potassium 2-(2,5-dioxo-5-phenylpentanoyl)hydrazine-1-carbodithioate **8** with an aqueous solution of potassium hydroxide in water at reflux for 2 hours. The reaction mixture was treated with dilute hydrochloric acid to pH = 4. The solid obtained was recovered by filtration, washed with water and recrystallized to give white 1-phenyl-4-(5-thioxo-4,5-dihydro-1,3,4-oxadiazol-2-yl)butane-1,4-dione **9** in 62% yield, with a melting point of 170-172 °C. The latter was exploited by two routes:

Route 1: a mixture of 1-phenyl-4-(5-thioxo-4,5-dihydro-1,3,4-oxadiazol-2-yl)butane-1,4-dione **9**, phenacyl bromide in acetone was heated under reflux for 6 hours to give 1-(5-((2-oxo-2-phenylethyl)thio)-1,3,4-oxadiazol-2-yl)-4-phenylbutane-1,4-dione **10** in 50% yield and melting point 148-150 °C.

Route 2: a solution of 1-phenyl-4-(5-thioxo-4,5-dihydro-1,3,4-oxadiazol-2-yl)butane-1,4-dione **9** with sodium hydroxide in ethanol and ethyl iodide was added to the solution, the mixture was heated under reflux for 6 hours to give 1-(5-(ethylthio)-1,3,4-oxadiazol-2-yl)-4-phenylbutane-1,4-dione **11** in 60% yield and a melting point of 188-190 °C.

The docking simulation results with PDBID:4hqd and PDBID:5h38 confirmed the antitumor activity of the synthesized heterocyclic against HepG2 and MCF-7 cell lines. Moreover, it demonstrated different binding affinity, thus confirming the experimental results.

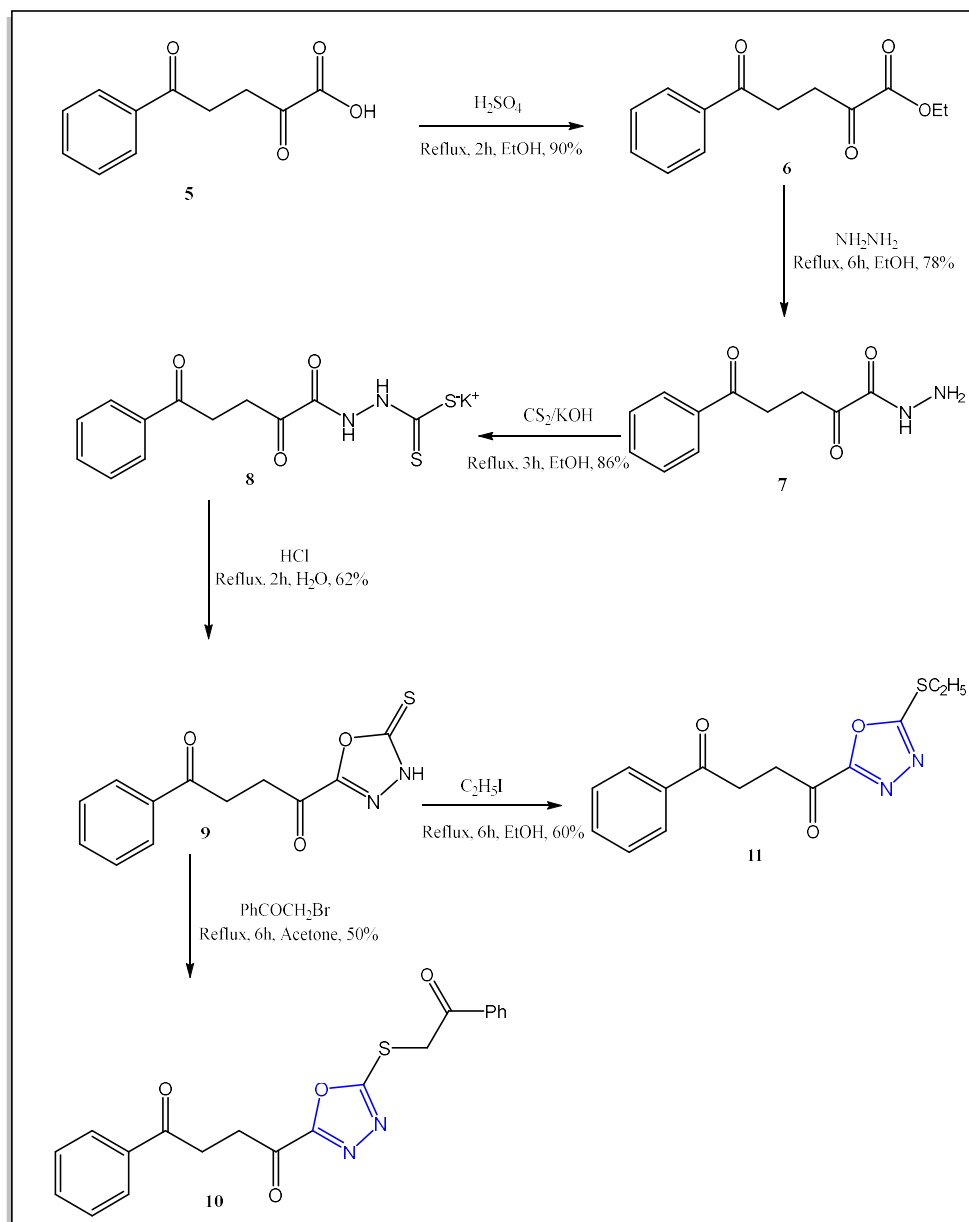

Scheme 5. Synthesis of 1,3,4-oxadiazole analogs by Hala E.M. Tolan et al.

Chao Fan et al.⁴³ produced N-(4-bromophenyl)-3-(5-(4-chloro-3-nitrophenyl)-1,3,4-oxadiazol-2-yl)benzenesulfonamide **18** by a series of reactions. First, chlorosulfonic acid were combined with benzoic acid **12** at reflux at 110 °C for 4 hours, the white solid **13** was filtered, washed and recrystallized in 82.2% yield. Next, pyridine, bromoaniline, acid **13** were dissolved in ethyl acetate at 0 °C, the reaction mixture was heated to room temperature to give pink solid **14** in 81.8% yield. Next, **15** was prepared by reacting of **14**, methanol and concentrated sulfuric acid, the mixture was heated at reflux for 2 h to give a white solid **15** in 88.5% yield. Subsequently, the latter **15**, methanol and hydrazine hydrate were heated under reflux for 2 hours to give a white solid **16** in 71.6% yield. Compound **17** was produced by refluxing **16**, an aldehyde derivative and a catalytic amount of glacial acetic acid for 1 hour to give a white solid **17** in 77.9% yield. Finally, condensation of **17**, t-BuOK, I₂ and ethyl acetate at reflux at 60 °C for 8 hours gave a white solid **18** in 56.3% yield and a melting point of 285.3-286.9 °C. The synthesized compound showed IC₅₀ = 70.51 ± 0.2 μM against Mtb LeuRS and MIC = 53.57 ± 0.2 μg/ml against Mtb H37Ra.

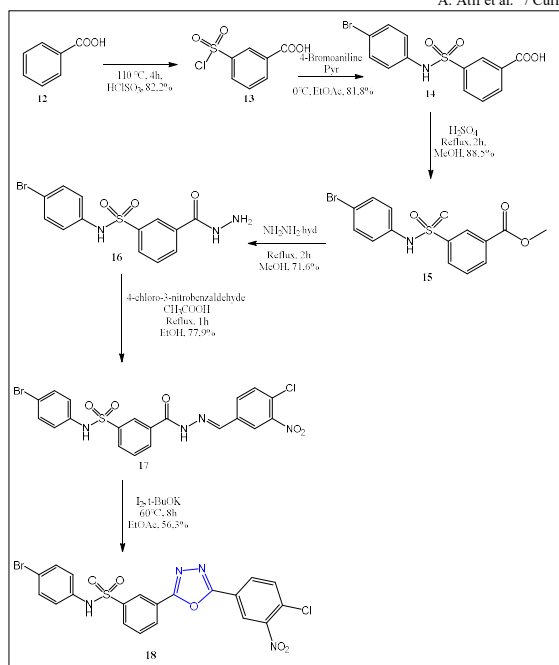

Scheme 6. Synthesis of 1,3,4-oxadiazole analogs by Chao Fan et al.

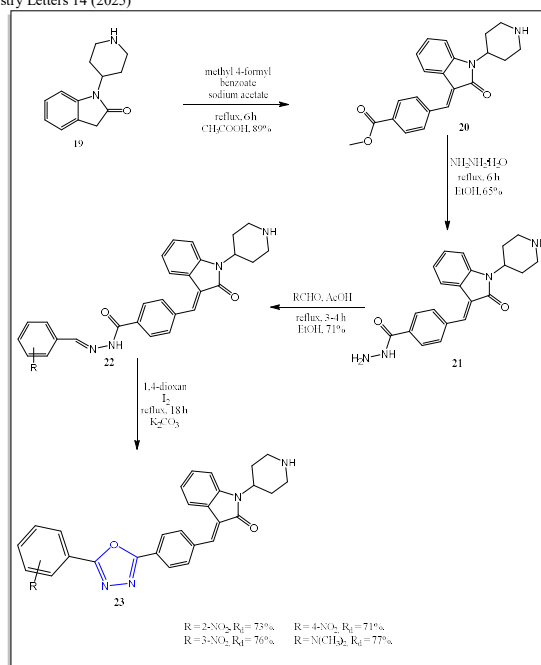

Scheme 7. Synthesis of 1,3,4-oxadiazole analogs by Abdullah Yahya Abdullah Alzahrani et al.

Abdullah Yahya Abdullah Alzahrani et al.⁴⁴ treated 1-(piperidin-4-yl)indolin-2-one **19** with methyl 4-formylbenzoate in acetic acid in the presence of sodium acetate at reflux for 6 h to give brown (E)-4-((2-oxo-1-(piperidin-4-yl)indolin-3-ylidene)methyl)benzoate **20** in 89% yield. Next, ester **20** was reacted with hydrazine hydrate in ethanol at reflux for 6 hours to give (E)-4-((2-oxo-1-(piperidin-4-yl)indolin-3-ylidene)methyl)benzohydrazide **21** of a yellowish-brown color in 65% yield. The latter **21** was condensed with various benzaldehydes to give **22** of a light gray color in 71% yield, which underwent oxidative cyclization using potassium carbonate and iodine in 1,4-dioxane to produce indole-bearing 1,3,4-oxadiazole analogs **23**. The inhibition of all compounds was different, ranging from 0.80 ± 0.20 to 12.50 ± 0.40 μM (against acetylcholinesterase) and from 1.10 ± 0.20 to 20.30 ± 0.10 μM (against butyrylcholinesterase), compared with the standard inhibitor donepezil (IC₅₀ values of 2.16 ± 0.12 and 4.5 ± 0.11 μM , respectively). All compounds were studied in structure-activity relationship, which was mainly influenced by the nature, number, position and electron-donating or electron-withdrawing effect of the substituent(s) on the phenyl ring.

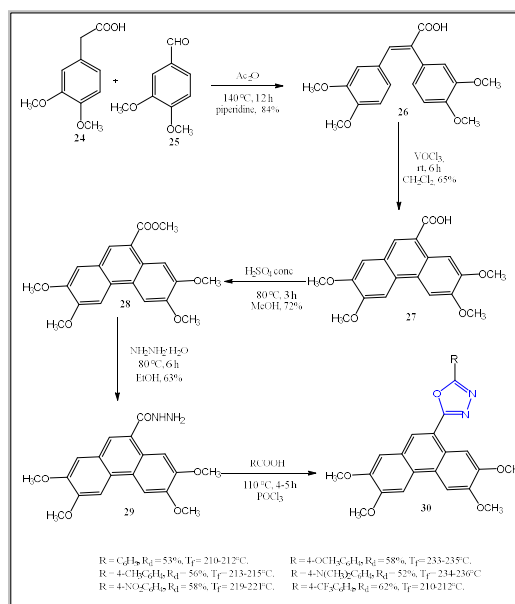

Scheme 8. Synthesis of 1,3,4-oxadiazole analogs by Ramesha Thongolla et al.

Ramesha Thongolla et al.⁴⁵ synthesized (E)-2,3-bis(3,4-dimethoxyphenyl)acrylic acid **26** by reacting a mixture of 2-(3,4-dimethoxyphenyl)acetic acid **24**, 3,4-dimethoxybenzaldehyde **25**, acetic anhydride and piperidine under reflux heating for 12 hours to produce **26** as a white solid in 84% yield. Next, anhydrous VOCl_3 was added to (E)-2, 3-bis (3, 4dimethoxyphenyl) acrylic acid solution **26** in CH_2Cl_2 with stirring at room temperature for 6 hours to form acid **27** as a light yellow solid in 65% yield. Then, the latter **27** was heated to reflux at 80 °C for 3 hours in methanol and concentrated H_2SO_4 to give a yellow solid **28** in 72% yield. Subsequently, hydrazine hydrate was added to a stirred solution of methyl 2,3,6,7-tetramethoxyphenanthrene-9-carboxylate **28** in EtOH with reflux heating at 80 °C for about 6 hours to form hydrazide **29** in 63% yield. Finally, condensation of the latter **29** with various carboxylic acids under reflux in phosphoryl trichloride POCl_3 for 4-5 hours at 110 °C gave the 1,3,4- oxadiazole analogs **30**. These phenanthrene-linked 1,3,4-oxadiazole analogs provide an interesting new target for the development of antibacterial agents and support their biological activities, which is confirmed by the binding energy values with the enzyme β -ketoacyl-acyl transporter protein synthase III (FabH). The newly synthesized analogues were evaluated for their in vitro antibacterial and antifungal activities against Gram-positive and Gram-negative bacteria as well as fungal strains. They demonstrated moderate antimicrobial activity.

Swadhapriya Bhukta et al.⁴⁶ were able to synthesize 1,3,4- oxadiazole analogs from **31** and **32** in DMSO in the presence of I_2 and K_2CO_3 under reflux at 90 °C. This method allows to obtain a wide variety of substrates with moderate to good yields and is well suited for functional groups. In addition, a key drug substance, fenadiazole, was extracted using this method.

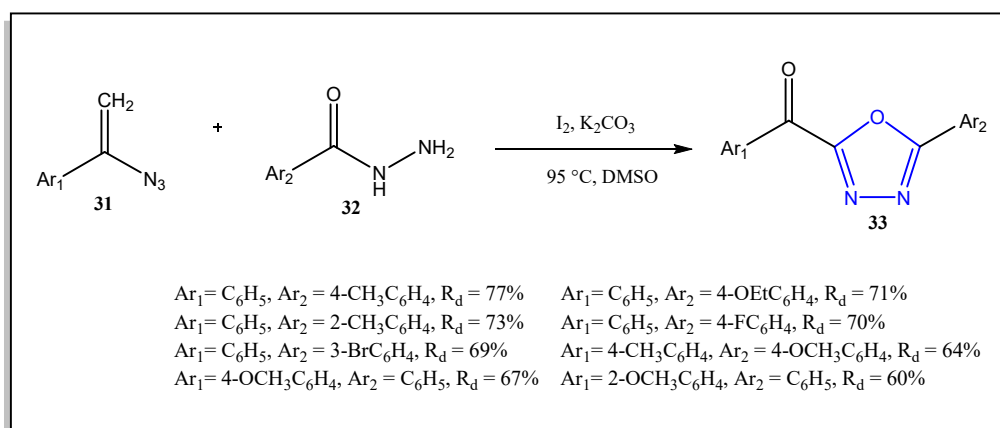

Scheme 9. Synthesis of 1,3,4- oxadiazole analogs by Swadhapriya Bhukta et al.

Manasa A. Doddagaddavalli et al.⁴⁷ demonstrated the synthesis of N'-(2-chloroacetyl)thiophene-2-carbohydrazide **35** by condensation of thiophene-2-carbohydrazide **34**, ethyl acetate and chloroacetyl chloride at room temperature for 1 hour, where a pale pink precipitate was formed with a melting point of 68-70 °C. The latter **35** was heated to 40 °C with phosphoryl trichloride for 2 hours to give **36** with a melting point of 70-72 °C. This product is an intermediate in the production of 1,3,4- oxadiazole analogs that exhibit remarkable antiproliferative activity and a surprisingly selective inhibitory effect compared to the standard. This particular selectivity could be explained by the synergistic effect of increased cellular uptake and higher ROS production in cancer cells after irradiation. The developed molecules met the criteria of drug similarity and ADME.

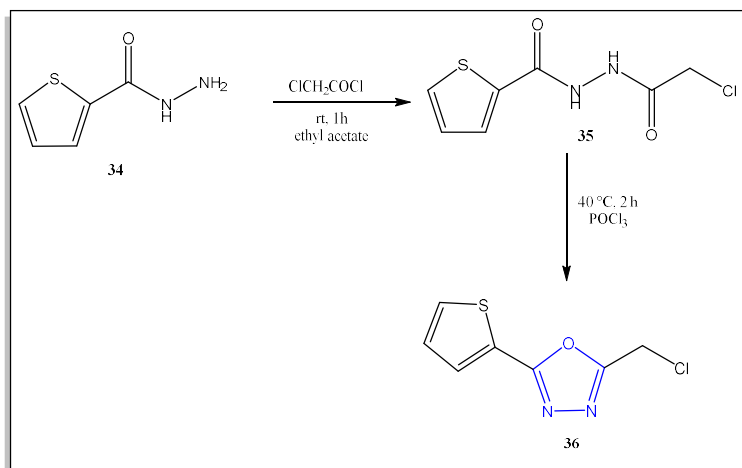

Scheme 10. Synthesis of 1,3,4- oxadiazole analogs by Manasa A. Doddagaddavalli et al.

Ju Peng et al.⁴⁸ chose as reagents for the synthesis of (E)-4-(3,5-dimethoxystyryl)phenol, $(\text{CH}_3\text{O})_2\text{SO}_2$, K_2CO_3 and CH_3COCH_3 to obtain **38** in 36% yield. Next, the latter **38**, potassium carbonate, N, N-dimethylformamide and ethyl bromoacetate were added in a reflux flask at 120 °C for 6 hours to give a white solid **39** in 96-98% yield. Next, **39**, absolute ethanol and hydrazine hydrate were heated to reflux at 120 °C for 6 hours to form a white precipitate **40** in 92-94% yield. Finally, the latter **40**, potassium hydroxide, absolute ethanol and carbon disulfide were heated under reflux for 8-10 hours to give **41** in 91-93% yield. These products are resveratrol-derived compounds, which are mainly composed of natural resveratrol. Most of the compounds have exceptional antibacterial properties to combat rice bacterial diseases, which seriously jeopardize the development of the global rice industry.

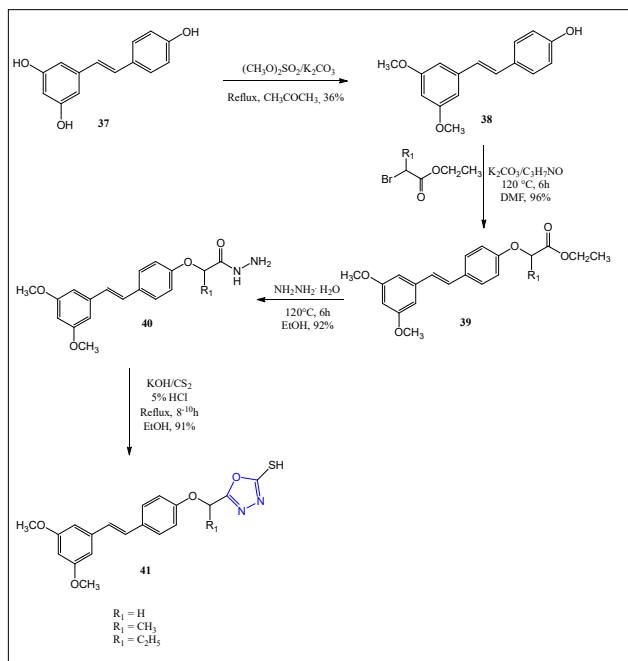

Scheme 11. Synthesis of 1,3,4- oxadiazole analogs by Ju Peng et al.

Wenlian Xie et al.⁴⁹ have described a method for synthesizing 1,3,4-oxadiazole polymers. Polyphosphoric acid was heated to 90 °C until completely melted. Next, terephthalic dihydrazide **42** was gradually added with heating over one hour, giving a homogeneous solution. On reaching 120 °C, polycondensation of the hydrazide groups occurred, leading to molecular chain growth. After four hours, the reaction solution changed from white to a light yellow liquid of medium viscosity, whose main component was a polyhydrazide macromolecule **43** as the temperature rose to 180 °C, the hydrazide group ($-\text{C}-\text{NH}-\text{NH}-\text{C}-$) of the prepolymer cyclized into a five-membered heterocycle, leading to an increase in viscosity and a color change from light yellow to brown yellow, forming 1,3,4-oxadiazoles **44**. This material has good mechanical characteristics, chemical inertness and thermal stability, as well as high strength and excellent toughness, making it a very promising material for membrane applications in the market.

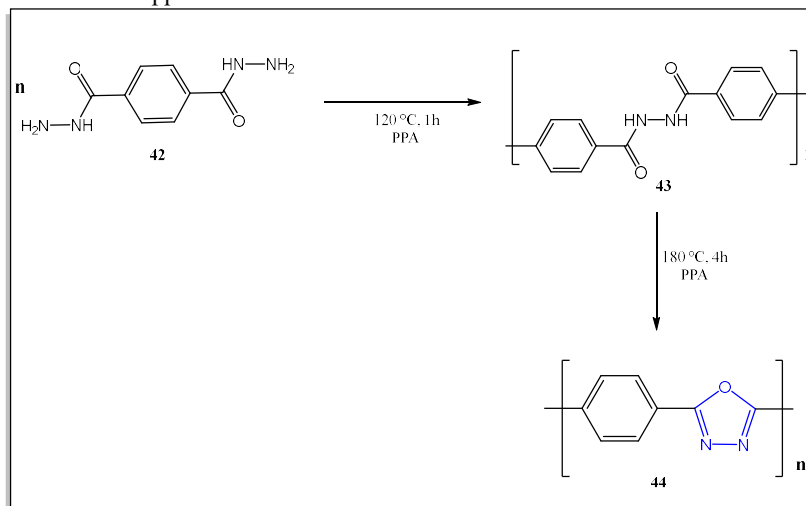

Scheme 12. Synthesis of 1,3,4- oxadiazole analogs by Wenlian Xie et al.

Simone Gastaldi et al.⁵⁰ synthesized **46** by treating 2-chlorophenylacetic acid **45** with CDI and hydrazine monohydrate in THF at room temperature with stirring for 18 h to give the white 2-(2-chlorophenyl)acetohydrazide **46** in 85% yield. The latter **46** and CDI were dissolved in THF and stirred at room temperature for 18 hours to give 5-(2-chlorobenzyl)-1,3,4-oxadiazol-2(3H)-one **47** as a white solid in 90% yield. This method has simple operating conditions and excellent yield.

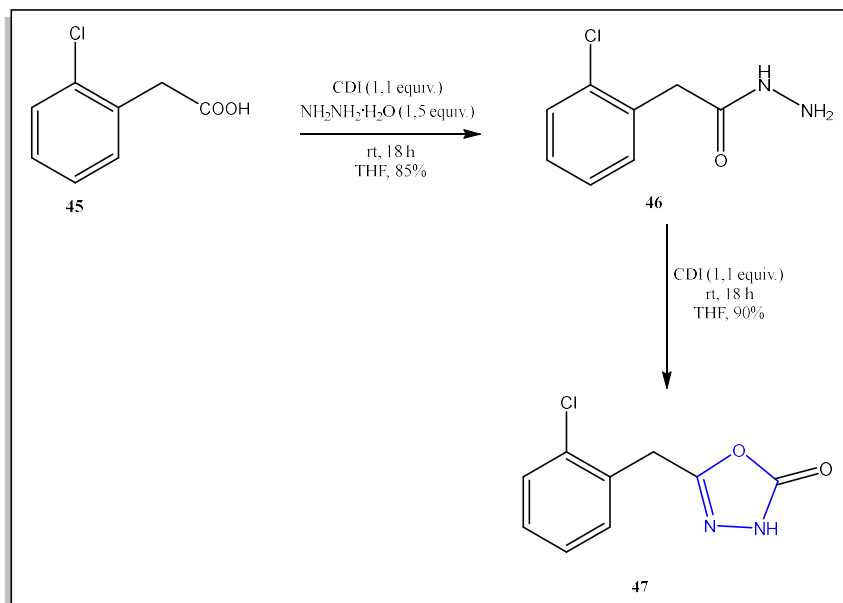

Scheme 13. Synthesis of 1,3,4- oxadiazole analogs by *Simone Gastaldi et al.*

Aisha Hossan et al.⁵¹ performed the synthesis of 4'-(hexyloxy)-[1,1'-biphenyl]-4-carbonitrile by the reaction of 4'-hydroxy-[1,1'-biphenyl]-4-carbonitrile **48**, potassium carbonate, iodohexane, and potassium iodide in dimethylformamide at reflux for 12 hours at 70 °C to give a white solid **49** in 74% yield. The latter **49** was reacted with NaN₃, lithium chloride, and N-methyl-2-pyrrolidone at reflux at 130 °C for 3 days to provide a white residue **50** in 86% yield. Finally, a mixture of 5-(4'-(hexyloxy)-[1,1'-biphenyl]-4-yl)-1H-tetrazole **50**, pentafluorobenzoic acid and N,N'-dicyclohexylcarbodiimide was added to N-methyl-2-pyrrolidone at reflux at 130 °C for 3 hours to give a white solid **51** in a yield of 72%. The aromatic nucleophilic substitution (ARNS) reaction was used to synthesize these highly fluorinated organogelators in high purity and good yields with significant photophysical, solvatochromic, and solvatofluorochromic properties.

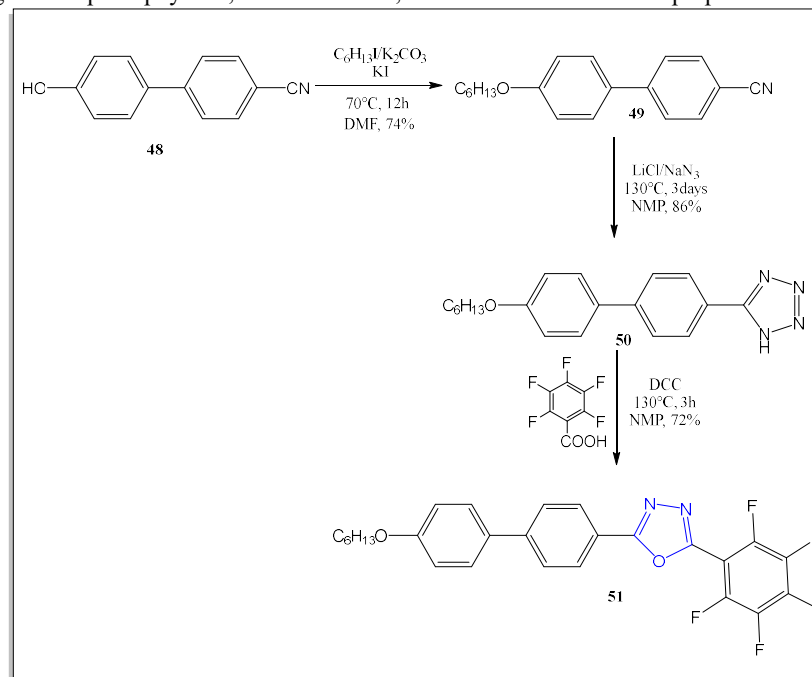

Scheme 14: Synthesis of 1,3,4-oxadiazole derivatives by *Aisha Hossan et al.*

P. Bharath Rathna Kumar et al.⁵² describe the synthesis of 1,3,4-oxadiazole analogs, first, ethyl 4,4,4-trifluoro-3-oxobutanoate **53**, phenylhydrazine **52** in glacial acetic acid were refluxed for 2 hours, the formed solid **54** was filtered, washed and recrystallized to give a yellow solid **54** in 85% yield and melting point at 114-115 °C. Then, ester **54** was refluxed for two hours at 70 °C with hydrazine hydrate in ethanol to obtain bright red solid **55** in 60% yield and melting point at 96–97 °C. Then, compound **55** was combined with aldehyde derivatives in the methanol with a few drops of acetic acid and refluxed for 2–3 hours at 70 °C. Finally, excess acetic anhydride was added to the recrystallized compound **56** and refluxed for 3–4 hours to obtain 1,3,4-oxadiazole analogs **57**. The synthesized compounds showed interesting antibacterial activity against Gram-positive (*Bacillus subtilis*, *Staphylococcus aureus*) and Gram-negative (*Pseudomonas aeruginosa* and *Escherichia coli*) microbes using cup and MIC techniques, moderate antifungal activity against *Aspergillus niger* and *Candida albicans*, with ampicillin and amphotericin B serving as standard references, and significant antioxidant potential in the DPPH test.

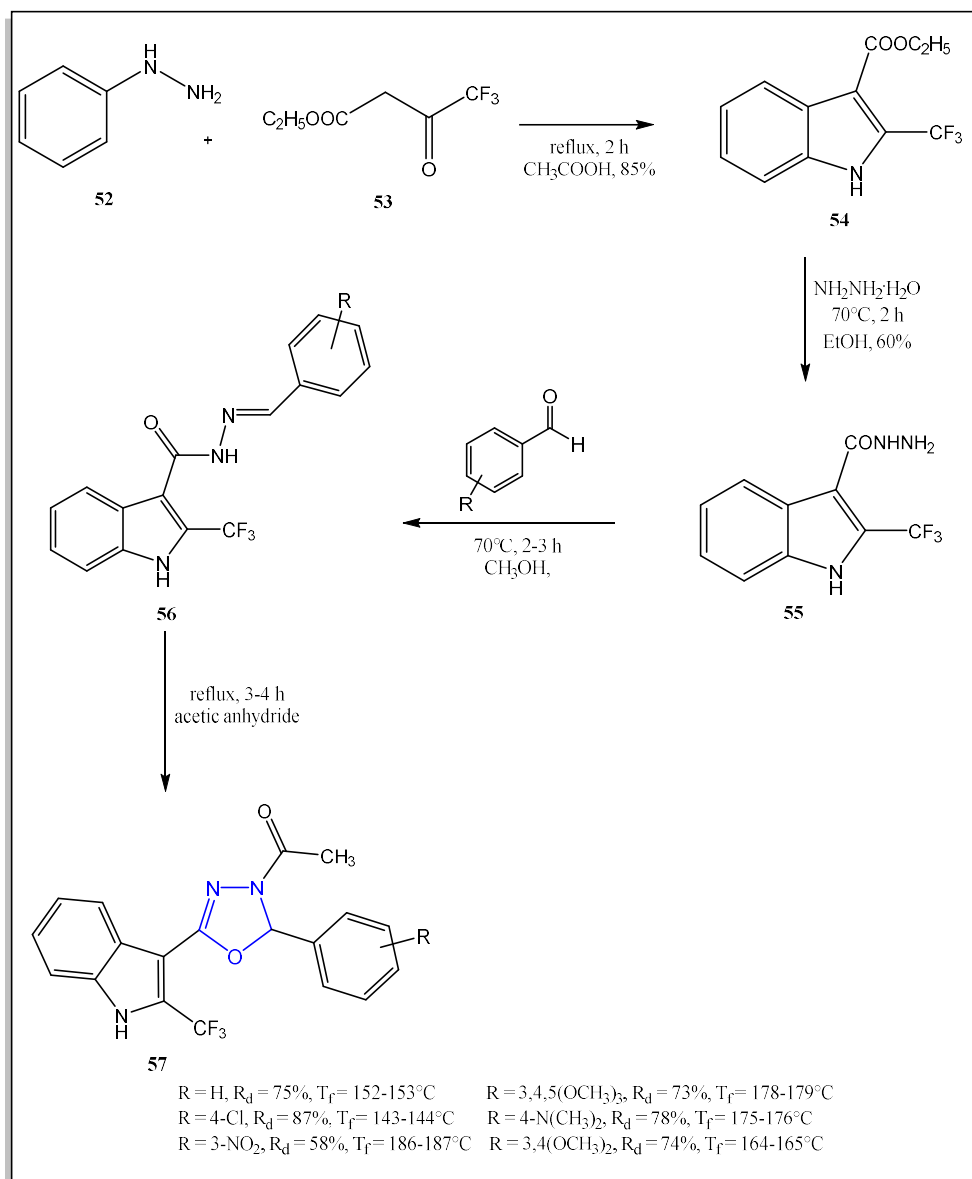

Scheme 15. Synthesis of 1,3,4-oxadiazole analogs by P. Bharath Rathna Kumar et al.

Ajay Singh Bisht et al.⁵³ studied the synthesis of 5-(pyridin-3-yl)-1,3,4-oxadiazol-2-amine by condensing hydrazinecarboxamide **59**, nicotinic acid **58** and concentrated sulfuric acid under reflux, the solid formed was filtered, washed and recrystallized in 68% yield and melting point 150-155 °C. The operating conditions of this method are simple and the synthesized compounds were tested for their ability to capture free radicals in vitro by DPPH and showed promising results. It is possible that these results will be an essential study for the creation of new therapeutic drugs in the future.

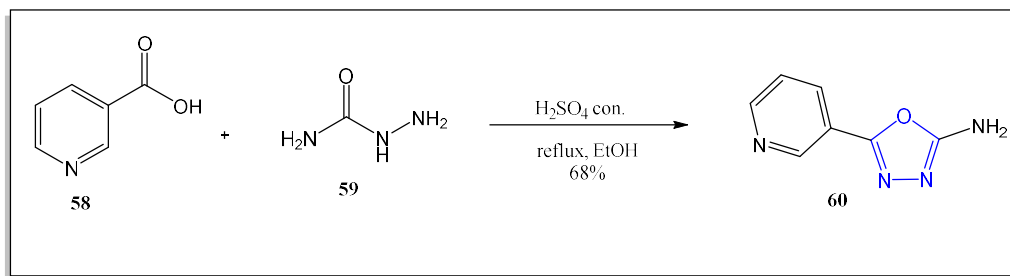

Scheme 16. Synthesis of 1,3,4- oxadiazole analogs by *Ajay Singh Bisht et al.*

Kingshuk Mahanty et al.⁵⁴ prepared 1,3,4- oxadiazole analogs by the reaction of hydrazide derivative **61**, CuI and LiClO₄ in DMF in a dipole electrochemical cell with constant current (15 mA) for 1.5 hours at 100 °C to give **62**. The electrochemical method used for the synthesis of N-sulfonyl amidines and 1,3,4-oxadiazoles is characterized by the activation of the DMF molecule. The successful use of electro-redox in the dehydrative coupling and oxidative cyclization reactions eliminates the need for stoichiometric chemical oxidants and reduces the production of reagent waste. This protocol demonstrated a high tolerance to functional groups, offering a wide range of substrates with an isolated yield of 47–94%.

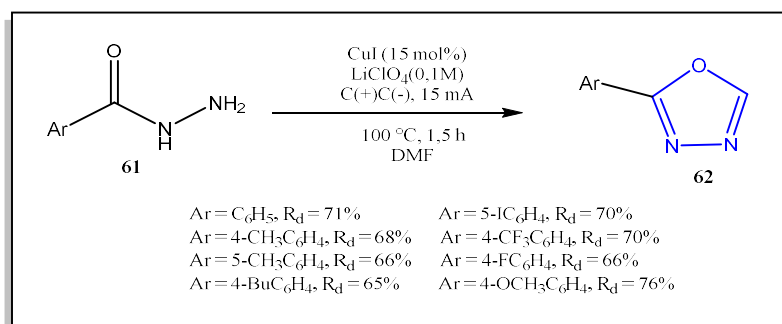

Scheme 17. Synthesis of 1,3,4- oxadiazole analogs by *Kingshuk Mahanty et al.*

Beate König et al.⁵⁵ reported the synthesis of 1,3,4- oxadiazole analogs by different procedures:

Procedure A: Benzylamine and 2-chlorpyrimidine-5-carbonitrile **63** were dissolved in ethanol, DIPEA was added and refluxed at 90 °C for 18 h to obtain 2-(benzylamino)pyrimidine-5-carbonitrile **64** as a yellow solid in 95% yield and melting point 170-172 °C. The latter **64**, NaN₃, NH₄Cl and LiCl·H₂O were suspended in DMF, the mixture was subjected to microwave irradiation at 150 W and 100 °C with vigorous stirring for 18 h. After removal of the solvent under reduced pressure, the crude tetrazole intermediate was dissolved in CH₂Cl₂ and difluoroacetic anhydride at room temperature for 18 h to give **65** as a white solid in 38% yield and melting point 174-176 °C. This procedure requires the use of microwave which makes the reaction environmentally friendly as it does not have any energy source.

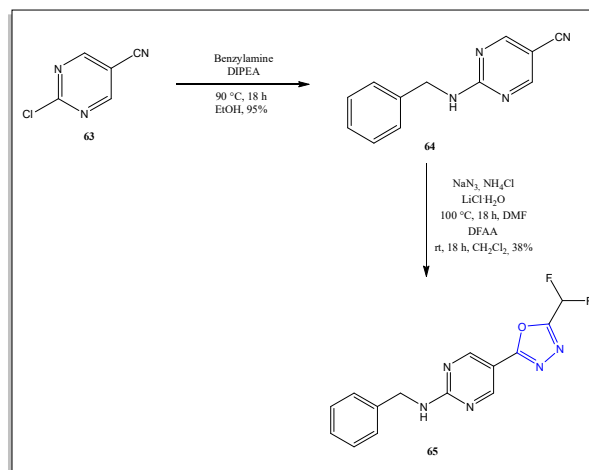

Scheme 18. Synthesis of 1,3,4- oxadiazole analogs by *Beate König et al.* (**procedure A**)

Procedure B: Methyl 4-(bromomethyl)benzoate **66** and butylamine were dissolved in THF, the reaction was stirred at room temperature for 1 h to give methyl 4-((butylamino)methyl)benzoate **67** as a colorless oil in 87% yield. Then, the latter **67** and benzoyl chloride were dissolved in DCM, the mixture was stirred at room temperature for 2 hours to give a yellow oil, which was dissolved in methanol with hydrazine monohydrate by refluxing at 70 °C for 3 hours. Then, the resulting hydrazide, DMF, DFAA and Et₃N were refluxed at 70 °C for 1 hour. Finally, the resulting difluoromethylacylhydrazide was taken up in THF, Et₃N and Burgess reagent were added and heated at 60 °C for 18 hours giving **68** as a white lyophilized solid in a yield of 15%. The advantage of this method is that it has a long duration and available raw materials.

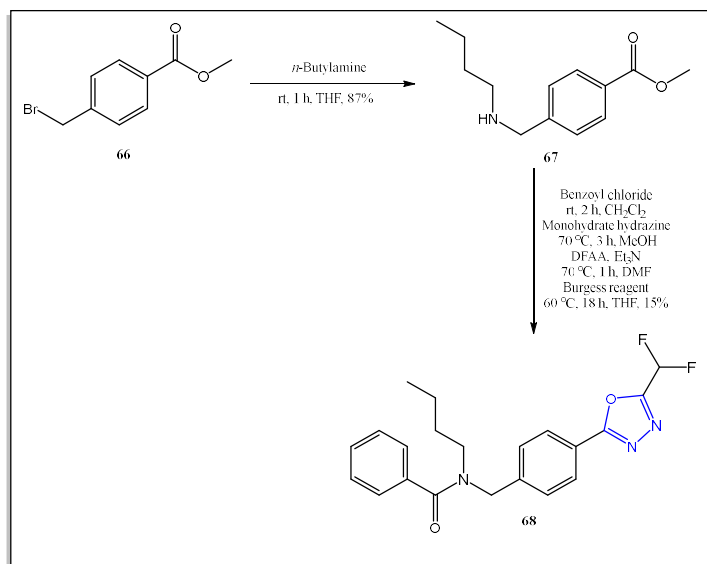

Scheme 19: Synthesis of 1,3,4- oxadiazole analogs by Beate König et al. (**procedure B**)

Procedure C: The reaction between compounds **69**, **70**, **71** and **72** in methanol in the presence of TEA at reflux for 72 hours gave methyl 4-((N-(2-(benzylamino)-2-oxoethyl)-4-(dimethylamino)benzamido)methyl)benzoate **73**. The latter **73**, NaN₃, NH₄Cl and LiCl·H₂O in DMF were refluxed at 100 °C for 18 hours. The tetrazole derivative formed was dissolved in toluene, DFAA was added and stirred at 70 °C for 18 hours to obtain a white lyophilized solid **74** in a yield of 9%. The advantage of this method is that it has raw materials available.

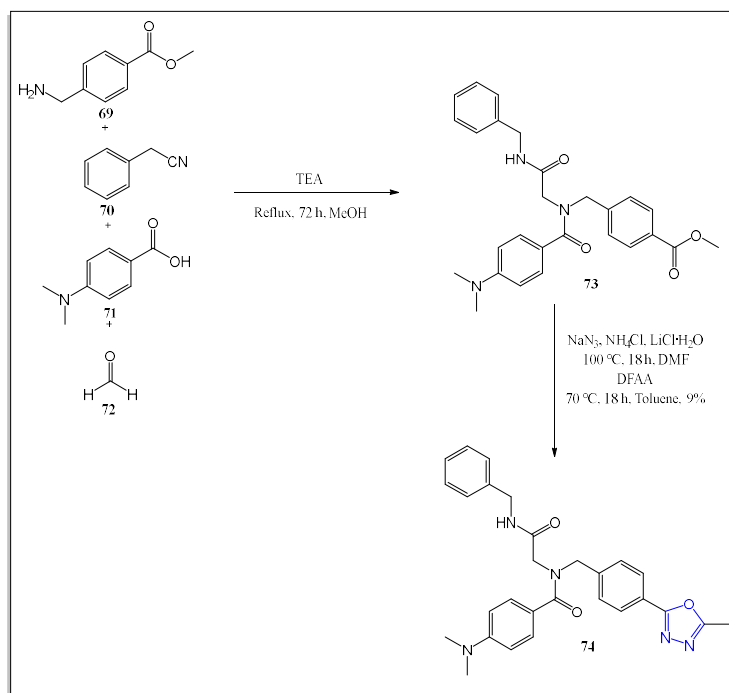

Scheme 20. Synthesis of 1,3,4- oxadiazole analogs by Beate König et al. (**procedure C**)

Az-eddine El Mansouri et al.⁵⁶ reacted a carboxylic acid derivative **75** with thionyl chloride in methanol at room temperature for 3 h to give esters **76**, then, ester derivative **76**, hydrazine hydrate and ethanol were refluxed for 3 h to give the desired product **77**. Finally, hydrazide **77**, chloroacetic acid, phosphorus oxychloride and DCE were refluxed at 80 °C for 12 h to give 1,3,4-oxadiazole analogs **78**. The cytotoxic activity of these compounds against fibrosarcoma (HT-1080), breast (MCF-7 and MDA-MB-231), lung carcinoma (A-549) and antiviral activity against SARS-CoV-2 were tested. All cell lines tested were inhibited, but all compounds tested did not demonstrate anti-SARS-CoV-2 activity, with an EC50 greater than 100 μ M.

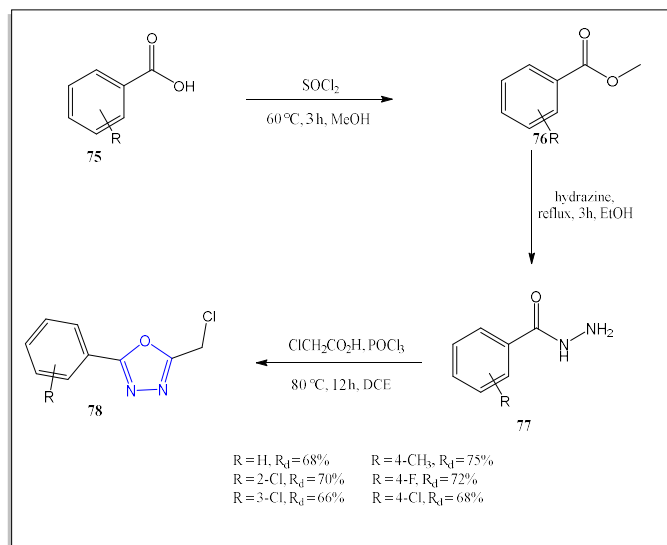

Scheme 21. Synthesis of 1,3,4-oxadiazole analogs by *Az-eddine El Mansouri et al.*

Heba E. Hashem et al.⁵⁷ successfully prepared 3-(5-(pyridin-3-yl)-1,3,4-oxadiazol-2-yl)-2H-chromen-2-imine by treating N¹-(2-cyanoacetyl)nicotinohydrazide **81** with salicylaldehyde in ethanol in the presence of a catalytic amount of ammonium acetate at reflux for 4 hours. The solid formed was filtered, washed and recrystallized to give 3-(5-(pyridin-3-yl)-1,3,4-oxadiazol-2-yl)-2H-chromen-2-imine **83** as reddish brown crystals in 65% yield and melting point 199-200 °C. The results of a molecular docking study showed that this compound has a higher binding capacity with the main protease enzyme of SARS-CoV-2. Moreover, ADME properties, in addition to pharmacokinetics and Lipinski rules, revealed that this newly synthesized compound follows Lipinski rules with high gastrointestinal absorption, making it a promising potential candidate for COVID-19.

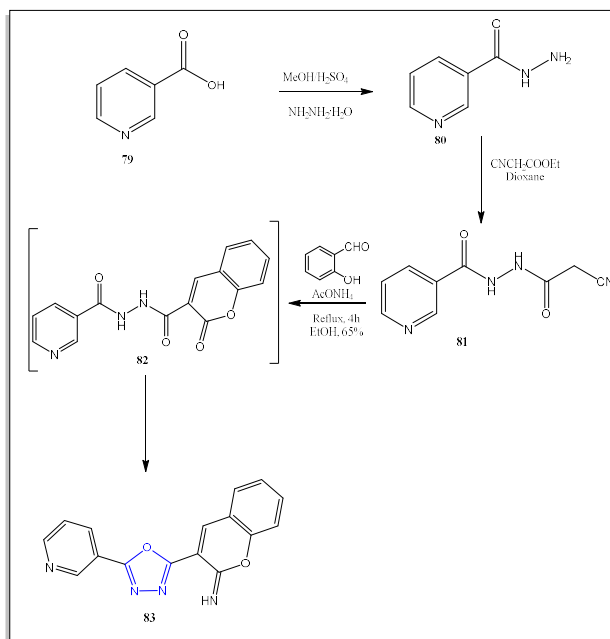

Scheme 22. Synthesis of 1,3,4-oxadiazole analogs by *Heba E. Hashem et al.*

Shouxing He et al.⁵⁸ described an efficient synthesis of (5-thioxo-4,5-dihydro-1,3,4-oxadiazol-2-yl)methyl hexylcarbamodithioate **89**. Hexan-1-amine **84**, NaOH and CS₂ were stirred in tetrahydrofuran at 120 °C for 3 hours to give sodium hexylcarbamodithioate **85**, the latter and methyl chloroacetate were stirred in tetrahydrofuran for 3 hours to give ester **86**, which was combined with hydrazine hydrate and refluxed for 3 hours to give hydrazide **87**, the latter was reacted with KOH and CS₂ in tetrahydrofuran for 3 hours to give **88**. (5-Thioxo-4,5-dihydro-1,3,4-oxadiazol-2-yl)methyl hexylcarbamodithioate **89** was obtained by refluxing **88** for 6 hours followed by acidification with HCl to a white to yellow solid with a melting point of 66.7-67.7 °C. They introduced this product as a flotation collector to separate malachite from quartz and calcite by flotation. During microflotation, he observed that this compound had higher flotation and selectivity for malachite than the traditional collector, octylhydroxamic acid, and enabled efficient separation and enrichment of malachite. Through contact angles, ζ potentials and UV spectra, it was proven that this product adhered particularly well to the malachite surface, and not to that of quartz and calcite.

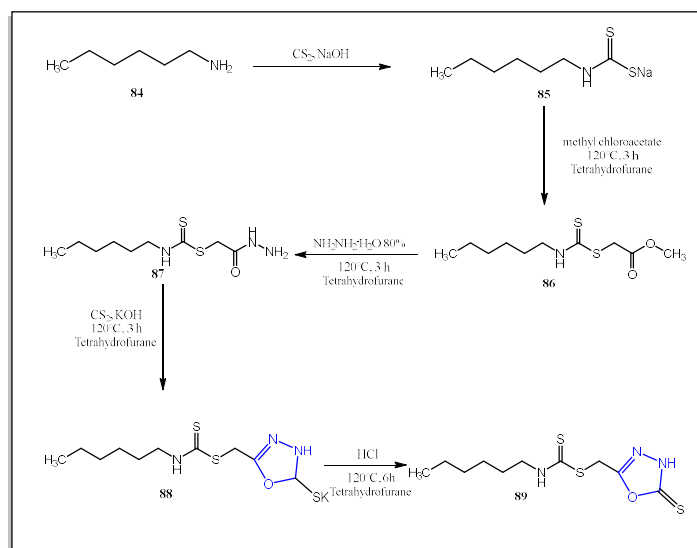

Scheme 23. Synthesis of 1,3,4- oxadiazole analogs by *Shouxing He et al.*

Mohamed Alaasar et al.⁵⁹ performed the esterification of **92** by condensing 4-(benzyloxy)benzoic acid **90** with 2,3,4,5,6-pentafluorophenol **91** in the presence of N,N'-dicyclohexylcarbodiimide and 4-methylaminopyridine in dichloromethane at room temperature for 72 hours, the resulting ester **92** was reacted with 4-hydroxybenzohydrazide in N,N-Dimethylformamide at room temperature for 48 hours to afford 4-(benzyloxy)-N'-(4-hydroxybenzoyl)benzohydrazide **93** which was cyclized using thionyl chloride (SOCl₂) at reflux for 4 hours under an argon atmosphere to afford 4-(5-(4-(benzyloxy)phenyl)-1,3,4-oxadiazol-2-yl)phenol **94**. This intermediate enables the creation of novel 1,3,4-oxadiazole-based tetracatenary LCs by incorporating stimulating molecular units into the polycatenary design, representing a promising strategy for the development of new functional LC materials. Depending on the length of the terminal chains, these compounds transform into 3D bicontinuous cubic (Cubbi) or columnar phases.

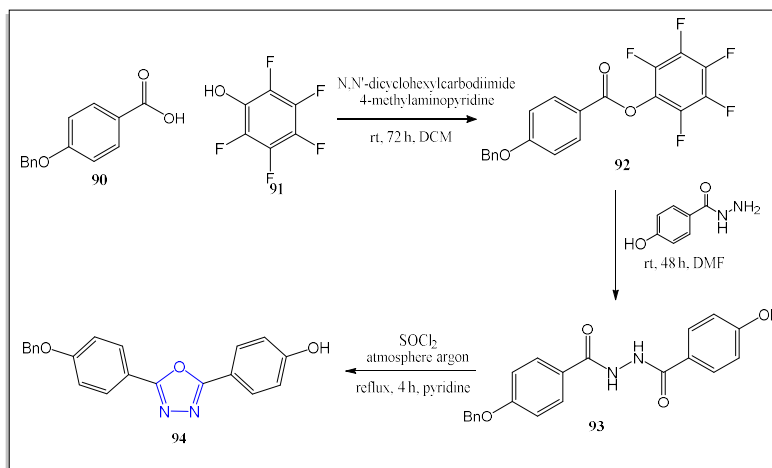

Scheme 24. Synthesis of 1,3,4- oxadiazole analogs by *Mohamed Alaasar et al.*

Aoyun Lu et al.⁶⁰ advocated a synthetic approach to 1,3,4-oxadiazole analogs, firstly, 8-benzyl-8-azabicyclo[3.2.1]octane-3-carboxylic acid **95** and p-toluenesulfonic acid were dissolved in ethanol and refluxed for 8 hours to give ethyl 8-benzyl-8-azabicyclo[3.2.1]octane-3-carboxylate **96** as a colorless oil in 88% yield. The latter **96** and hydrazine hydrate were heated in ethanol at reflux for 48 hours to give hydrazide **97** in 60% yield as a white solid. Then, a mixture of **97**, an aromatic carboxylic acid derivative, TEA, and T₃P was refluxed in EtOAc at 80 °C under a nitrogen atmosphere for 8 h to give **98**. Finally, **98** in MeCN was added to POCl₃ while refluxing for 12 h to give the 1,3,4-oxadiazole analogs **99**. All the tested compounds were tested in vitro for their nematocidal activity against *Bursaphelenchus xylophilus* and *Meloidogyne incognita*, and showed low to good nematocidal activity.

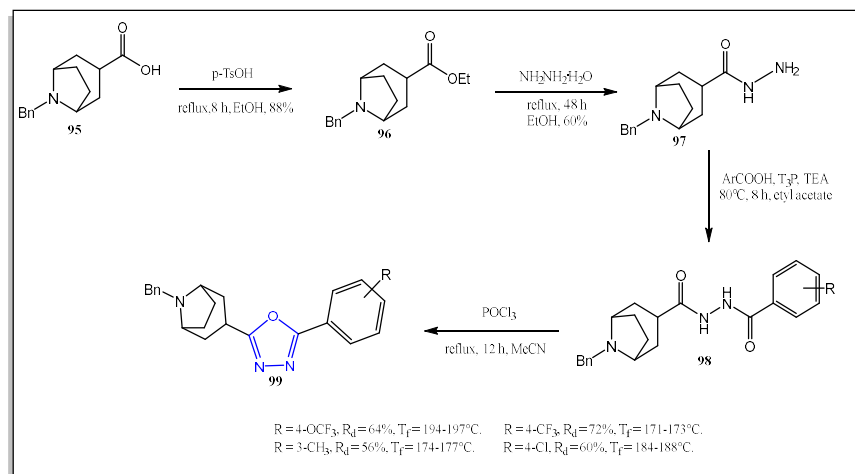

Scheme 25. Synthesis of 1,3,4-oxadiazole analogs by Aoyun Lu et al.

Shashikant V. Bhandari et al.⁶¹ have developed a simple method for the synthesis of 1,3,4-oxadiazole analogs by reacting o-phenylenediamine **100** and alpha-ketoglutaric acid **101** in the presence of HCl to give **102**, the latter having been treated with ethanol in the presence of H₂SO₄ to give ester **103** which was treated with hydrazine hydrate to produce 4-(1H-benzimidazol-2-yl)-4-oxobutanehydrazide) **104**. Under micro-irradiation -waves, hydrazide **104** was reacted with various acids in the presence of POCl₃ at a power level of 6 (60%, 420 W) for 6 to 13 minutes to form 1,3,4-oxadiazole analogs **105**. Substances containing 1,3,4-benzimidazole oxadiazole are an important class of compounds with a variety of biological activities. They have shown impressive antioxidant activity compared to their reference standard, ascorbic acid.

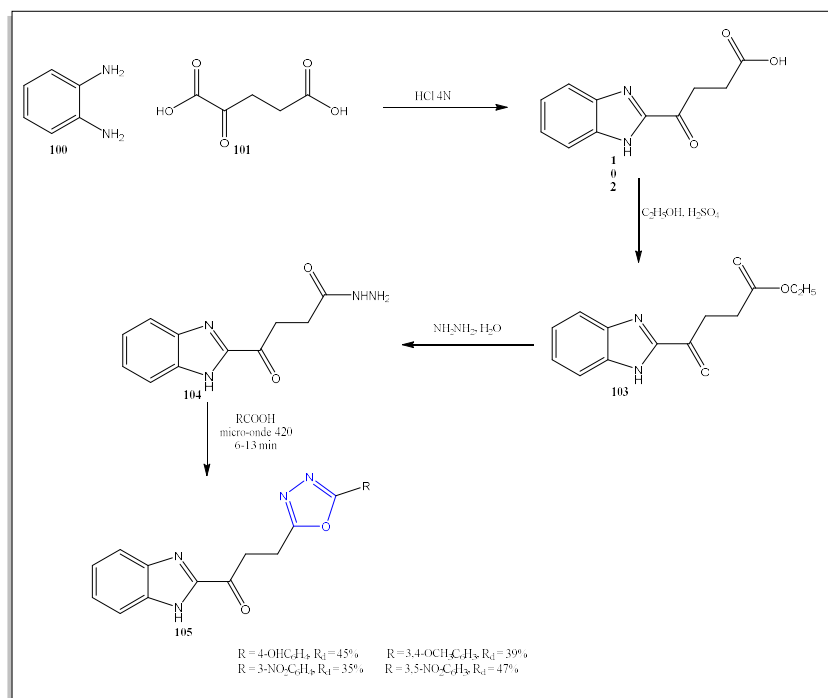

Scheme 26. Synthesis of 1,3,4-oxadiazole analogs by Shashikant V. Bhandari et al.

Robert Balogh et al.⁶² performed the synthesis of 1,3,4-oxadiazole analogs by condensing tetrazole **107** and **106** in dry pyridine refluxing at 130 °C for 24 h under an argon atmosphere. The precipitated product **108** was collected by filtration, washed and recrystallized. This method involves the preparation of small organic molecules by simply condensing commercially available tetrazoles and easily synthesized acyl chloride of the thiazolo[5,4-d]thiazole unit in a single method. An experimental study of the electronic properties of these derivatives was carried out using cyclic voltammetry. The studied compounds, which have low electron donating capacity and moderate to high electron accepting capacity, are probably not narrow band gap electron transport materials, since the UV-Vis and cyclic voltammetry results, supported by the theoretical study, indicate a wide band gap between the HOMO and LUMO orbitals of these compounds. Nevertheless, they may prove beneficial in wide band gap allowed semiconductors. The band gap of derivatives with electron-donating motifs is small and the intramolecular charge transfer in the visible light region is high, making them promising candidates for organic electronics.

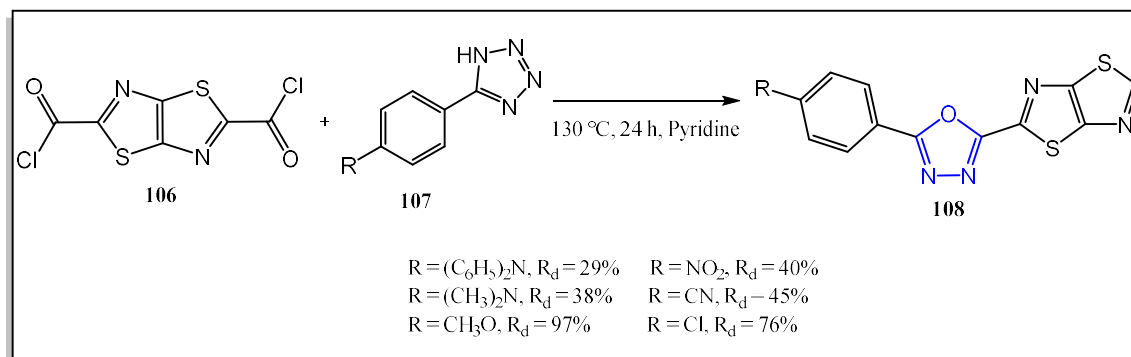

Scheme 27. Synthesis of 1,3,4-oxadiazole analogs by Robert Balogh et al.

Mario S.S. Oliveira et al.⁶³ performed an efficient procedure for the synthesis of 1,3,4-oxadiazole analogs by the reaction of **110** and an acid chloride derivative **109** in 5 mL of refluxing pyridine for 12 hours. The mixture was poured into ice-water, filtered under vacuum, washed and recrystallized to give **111**. They used DFT calculations to analyze the photophysical characteristics of the molecules. The measurement of excitation energy corresponds perfectly to the trend observed in the UV-Vis spectra. An increase in the first calculated hyperpolarizability ($\beta(0)$) is observed as pyridine groups are substituted for thiophenes.

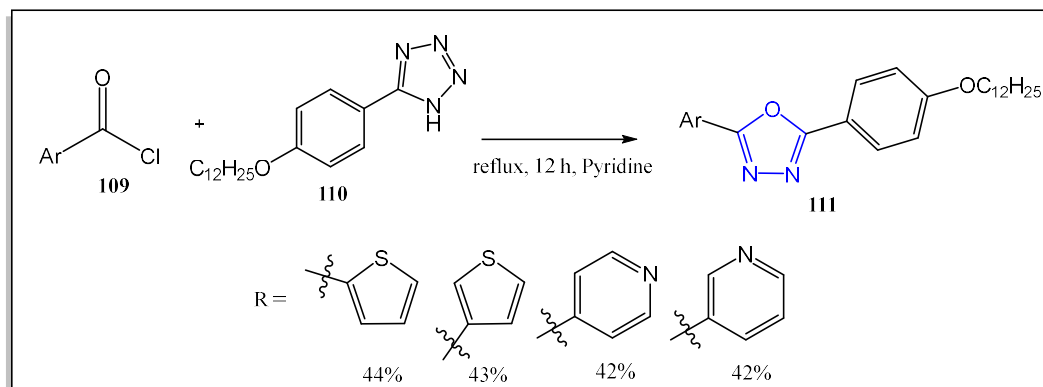

Scheme 28: Synthesis of 1,3,4-oxadiazole analogs by Mario S.S. Oliveira et al.

Vaclav Pflégr et al.⁶⁴ performed the condensation of **112** with hydrazine hydrate in methanol with stirring for 3 h at room temperature to give hydrazide **113** as a pale yellow oil. Then, pyrimidine-5-carbohydrazide **113** was dissolved in anhydrous acetonitrile and an alkyl isocyanate was added under reflux for 2 h to obtain **114**. Finally, this residue **114** was reacted with p-toluenesulfonyl chloride and triethylamine in dichloromethane for 6 h (up to 12 h) at room temperature to form **115**. In medicinal chemistry, molecular hybridization and isostery are proven methods, and so they have been employed to create new compounds that could be studied as potential antimycobacterials to combat drug-resistant strains. Hybrid pyrimidine-1,3,4-oxadiazoles are outstanding antimycobacterial agents that primarily inhibit *M. tuberculosis* strains without developing cross-resistance to current drugs, making them promising drug candidates.

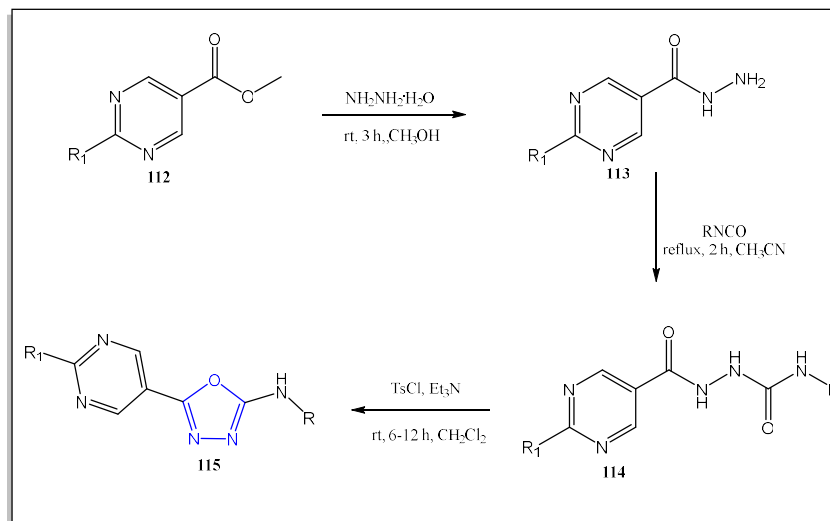

Scheme 29. Synthesis of 1,3,4-oxadiazole analogs by *Vaclav Pfler et al.*

Xiaoxiao Zheng et al.⁶⁵ reported an efficient four-step reaction sequence for the synthesis of (E)-1,2-bis(5-(3,5-dinitro-1H-pyrazol-4-yl)-1,3,4-oxadiazol-2-yl)diazene **120**, firstly, 3,5-dinitro-1H-pyrazole-4-carboxylic acid **116** was dissolved in methanol in the presence of thionyl chloride SOCl_2 to give ester **117**. Secondly, methyl 3,5-dinitro-1H-pyrazole-4-carboxylate **117** was added to ethanol with 85% hydrazine monohydrate under reflux for 8 hours to give **118** as a pale yellow solid in 68.5% yield. Third, the solution of KHCO_3 in H_2O was poured into the suspension of **118** in ethanol with BrCN with stirring for 24 hours at room temperature to give **119** as a light yellow solid in 62% yield. Fourth, KMnO_4 in H_2O was slowly added onto **119** in dilute HCl with stirring at 55°C for 5 hours to give the product **120** in 64% yield. Researchers are constantly on the lookout for energetic materials offering high detonation performance and low sensitivities. Compound **119** was created here, with high density and low sensitivity. The sharp increase in crystal density of **119** indicates that this compound exhibits a more compact packing pattern, which has a beneficial effect on detonation characteristics.

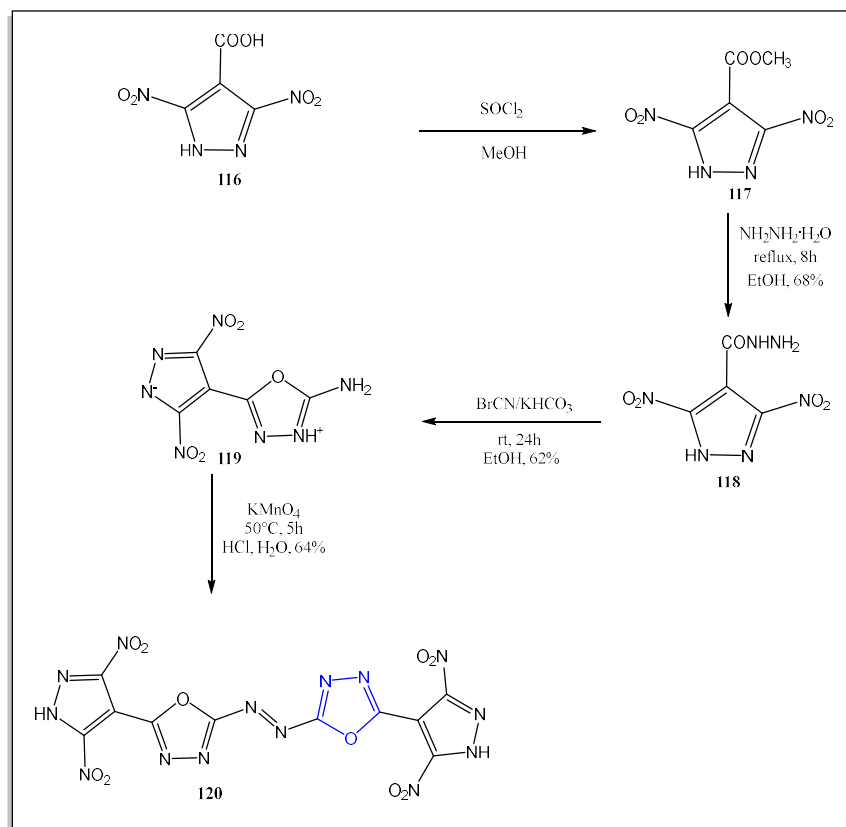

Scheme 30. Synthesis of 1,3,4-oxadiazole analogs by *Xiaoxiao Zheng et al.*

Daniel S. Verdoorn et al.⁶⁶ obtained 1,3,4-oxadiazole analogs by the condensation of p-toluenesulfonyl azide **121**, an acid derivative **122** and N-isocyanoinotriphenylphosphorane **123** in the presence of cobalt chloride CoCl_2 and MeCN under a nitrogen atmosphere at 60 °C in an oil bath for 16 h to afford **124**. The advantage of this method is that it's a one-step process using three components giving average to good yields.

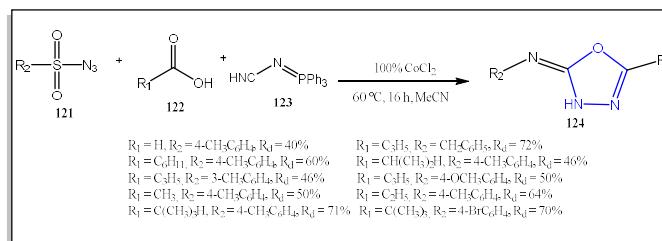

Scheme 31. Synthesis of 1,3,4-oxadiazole analogs by *Daniel S. Verdoorn et al.*

Abdulrahman I. Alharthi et al.⁶⁷ investigated the condensation reaction of 2-aminobenzhydrazide hydrazide **125** with aldehyde derivatives **126** in the presence of a reasonable amount (10 mol%) of 1% Zn-promoted Cu/CeO₂ catalysts (1% Zn-Cu/CeO₂) in aqueous ethanol in a ratio of 6:4 under reflux at 80 °C to give **127**. The impact of pure cerium oxide, zinc nitrate and copper nitrate on the yield and reaction time of 1,3,4-oxadiazole analogs was extensively investigated. Under optimal conditions, the model compound reached maximum yield (96%) in just 45 minutes. The aim is to design an affordable, reusable catalyst that can be easily used, generates numerous products and reacts rapidly.

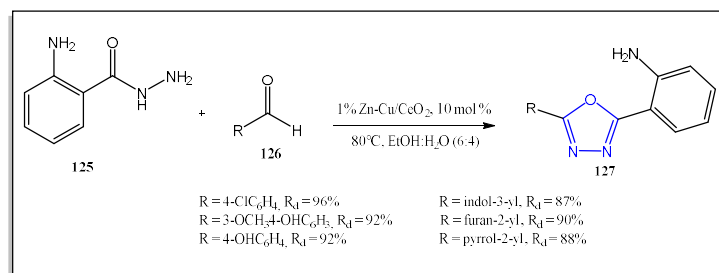

Scheme 32. Synthesis of 1,3,4-oxadiazole derivatives by *Abdulrahman I. Alharthi et al.*

Hua-Wen Meng et al.⁶⁸ proposed a synthetic route for 1,3,4-oxadiazole analogs by reacting terephthalaldehyde **129** with 2-hydroxyacetophenone **128** in absolute methanol in the presence of 10% NaOH solution while stirring at room temperature for 4 hours. Then, to a solution of **130** in DMSO, I₂ was added with refluxing at 110 °C for 12 hours to give **131**. Then, the latter **131** and a hydrazide derivative were dissolved in tert-butanol and stirred at 70 °C for 6 hours to give **132**. Finally, compound **132** was dissolved in dichloromethane with the addition of (diacetoxyiodo)benzene with stirring at room temperature for 6 hours. Flavonoids derived from 1,3,4-oxadiazole have demonstrated increased pharmacological efficacy. These substances have been shown to reduce oxidative stress and inflammation, providing a potential means of treating Parkinson's disease.

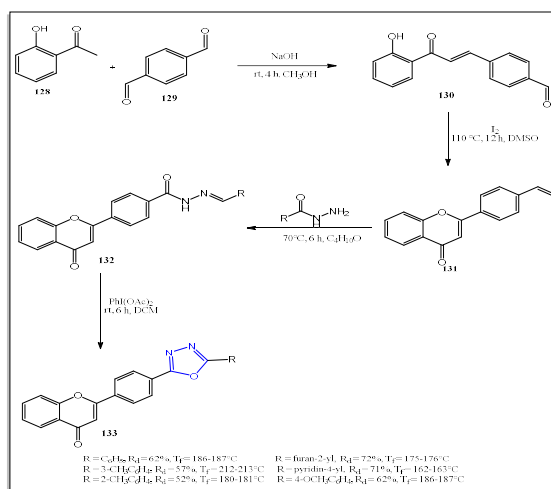

Scheme 33. Synthesis of 1,3,4-oxadiazole analogs by *Hua-Wen Meng et al.*

Valentin Karabelyov et al.⁶⁹ condensed equimolar amounts of a hydrazide derivative **134** and a carboxylic acid derivative **135** in the presence of HATU, DIEA, and Burgess's reagent in THF with stirring for 1–3 h to form **136**. These substances were prepared in high yields. According to the study, some of them demonstrated effective inhibition of hMAO-B *in vitro*, with a more significant inhibitory effect on the enzyme. On the other hand, all compounds tested at 1 μM showed no statistically significant inhibitory effect on hMAO-A activity.

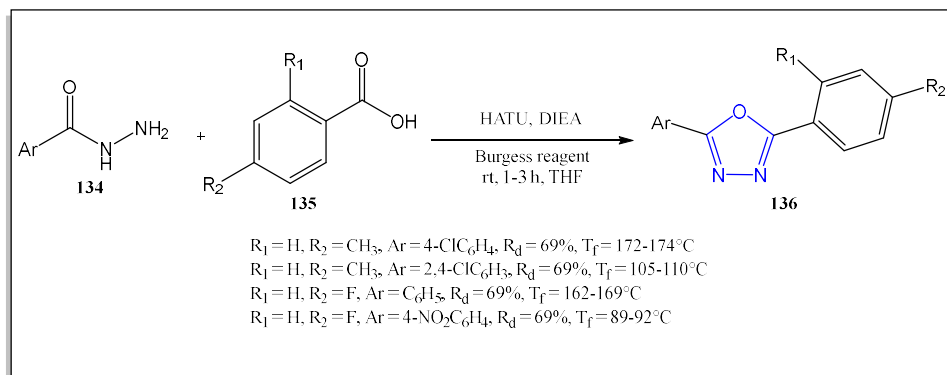

Scheme 34. Synthesis of 1,3,4-oxadiazole derivatives by *Valentin Karabelyov et al.*

Elham Rezaee et al.⁷⁰ developed a method for the synthesis of ethyl 5-(4-chloro-2-phenoxyphenyl)-1,3,4-oxadiazole-2-carboxylate **143**, firstly, 2,4-dichlorobenzoic acid **137** and phenol **138** were dissolved in DMF in the presence of potassium tert-butoxide and a catalytic amount of copper powder to give **139** in 88% yield and melting point at 164–166 °C. Then, **139** was dissolved in ethanol in the presence of concentrated sulfuric acid with refluxing for 24 hours to give **140** in 80% yield as an oil, which was treated with 10 mL of hydrazine hydrate (200 mmol) in 10 mL of ethanol with stirring for 12 hours at room temperature to give **141** in 84% yield and melting point at 100.5–102 °C. Subsequently, **141** was combined with ethylchloroglyoxylate in THF in the presence of triethylamine with stirring at room temperature for 3 hours to give **142** in 85% yield and melting point at 185–187 °C. Finally, **142** and P_2O_5 were added to toluene and refluxed for 3 hours to give **143** in 57% yield and melting point 93.8–94.3 °C. They succeeded in synthesizing these compounds in satisfactory yields, and their *in vitro* affinity for the rat brain benzodiazepine receptor was assessed by binding them to the radioligand. The results showed that the majority of the new compounds had affinities even higher than those of diazepam.

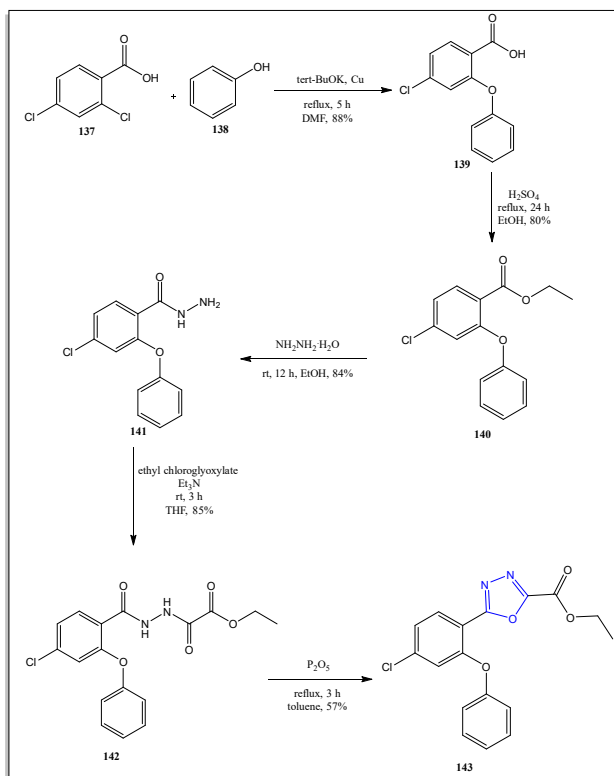

Scheme 35: Synthesis of 1,3,4-oxadiazole analogs by *Elham Rezaee et al.*

H. Maruthesh et al.⁷¹ were able to isolate 1,3,4-oxadiazole analogs by the condensation of 2-chloro-3-carbaldehyde derivative **144** with aqueous semicarbazide solution in ethanol in the presence of 5% acetic acid at reflux for 4 hours to give **145** which was reacted with aqueous ferric chloride refluxed at 80–90 °C for 5–6 hours to give **146**. The antimicrobial activity of all synthesized compounds was studied in vitro by diffusion in agar wells with gentamicin as antibacterial agent. Following the study, they are potentially antibacterial and antituberculous agents.

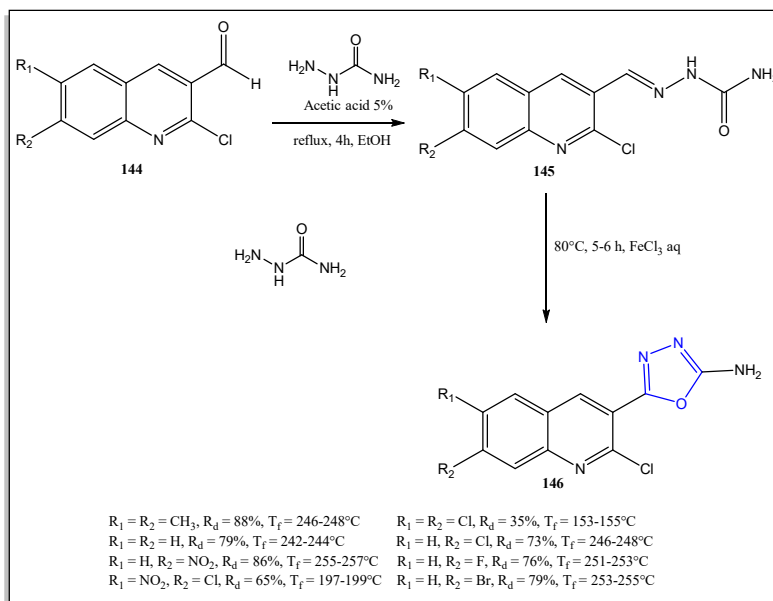

Scheme 36. Synthesis of 1,3,4-oxadiazole derivatives by *H. Maruthesh et al.*

Arshiya Banu Syeda et al.⁷² described the synthesis of 1,3,4-oxadiazole analogs by combining 2-amino-5-methylpyridin-3-ol **147** and 5-aminopyrimidine-2-carbaldehyde **148** in dry DMSO in the presence of Zn nanoparticles with stirring at 90 °C for 1 h to give **149** as a white solid in 76% yield and melting point 188-190 °C. Then, compound **149**, acetohydrazide, I_2 , and K_2CO_3 were heated in DMSO at 110 °C for 12 h to give **150** as a white solid in 67% yield and melting point at 223-225 °C. This product is used to synthesize biologically active compounds. They have been tested for their preliminary anticancer properties against different human cancer cell lines, such as prostate cancer, lung cancer, breast cancer, and colon cancer. These tests were performed using the MTT assay and chemotherapeutic agents such as etoposide as the reference drug. All drugs demonstrated greater efficacy against all cell lines compared to etoposide.

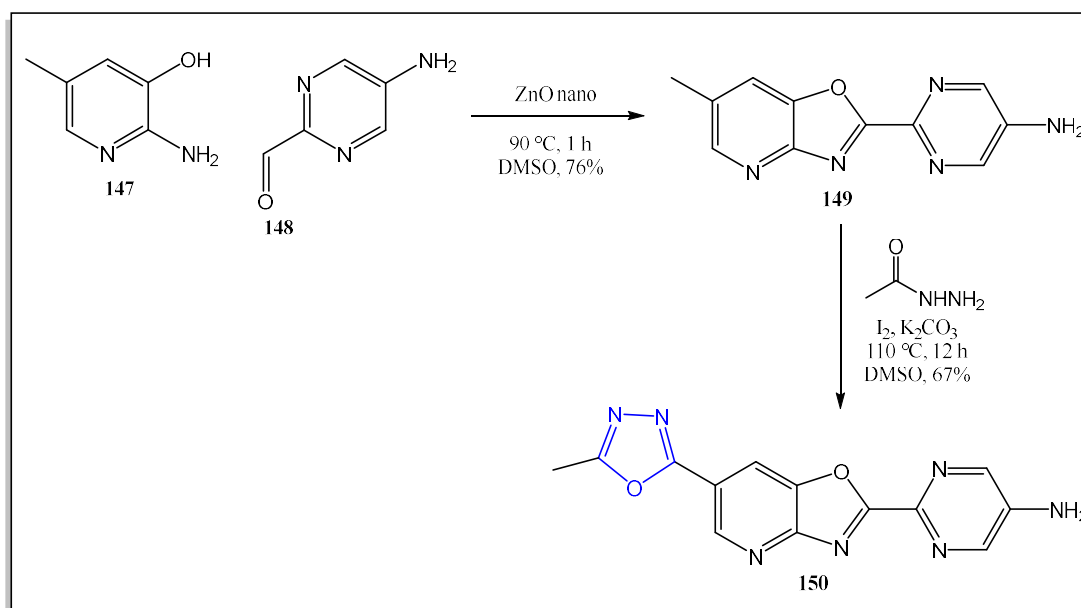

Scheme 37. Synthesis of 1,3,4-oxadiazole derivatives by *Arshiya Banu Syeda et al.*

Lohit Naik et al.⁷³ synthesized 1,3,4-oxadiazole analogs by the following method, a solution of ethyl naphtho[2,1-b]furan-2-carboxylate **151** in glacial acetic acid was stirred with bromine at 0 to 5 °C for 3 hours to give **152**, which was dissolved in ethanol with hydrazine hydrate under stirring and refluxed for 2 hours to give **153**, the hydrazide **153** was exploited by two routes:

Route 1: a mixture of 8-bromonaphtho[2,1-b]furan-2-carboxyhydrazide **153** and 4-fluorobenzoisothiocyanates in ethanol was refluxed for 3 hours to afford **154**, which was stirred in ethanol with aqueous NaOH and a solution of I₂ in KI (5% aqueous) until the iodine color persisted at room temperature followed by refluxing on a water bath to liberate 5-(5-bromonaphtho[2,1-b]furan-2-yl)-N-(4-fluorophenyl)-1,3,4-oxadiazol-2-amine **155** in 39% yield.

Route 2: To a solution of 8-bromonaphtho[2,1-b]furan-2-carboxyhydrazide **153** in dioxane, 4-methoxybenzaldehyde was added under reflux in a water bath for 2 h to form **156** which was suspended in glacial acetic acid with anhydrous sodium acetate and bromine with constant stirring until the color of bromine faded to give 2-(5-bromonaphtho[2,1-b]furan-2-yl)-5-(4-methoxyphenyl)-1,3,4-oxadiazole **157** in 47% yield.

The particularity of this method lies in the ability to perform two approaches by modifying the substrates and reagents. The studied photophysical characteristics of the fluorophores suggest that they could be used as promising candidates for organic light-emitting diode, solar cell and chemosensor applications.

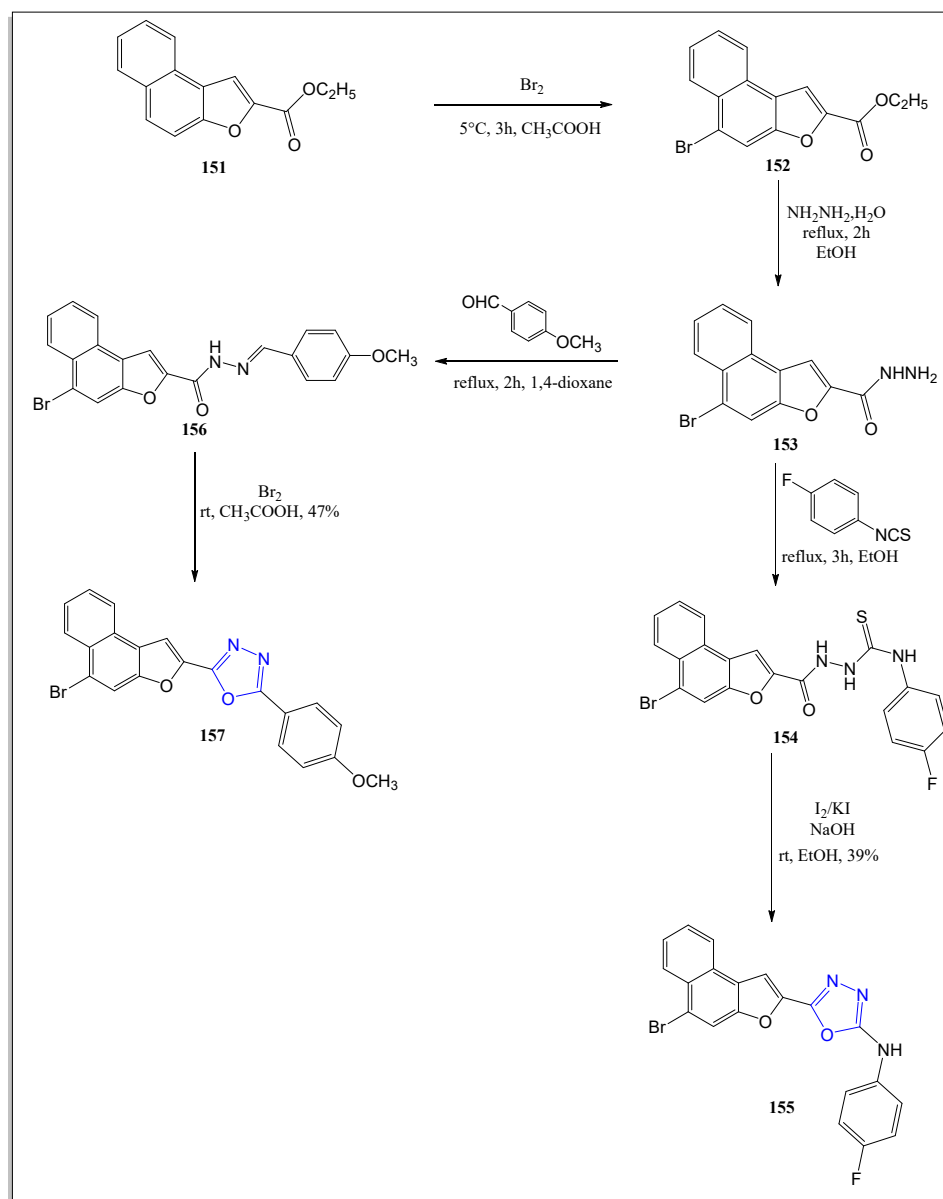

Scheme 38. Synthesis of 1,3,4-oxadiazole derivatives by Lohit Naik et al.

Raltegravir was synthesized by Francesco Caputo et al.⁷⁴ in several steps. Firstly, a mixture of **160**, methanesulfonic acid and 5% Pd/C (50% moisture) was mixed in an 8:1 methanol/water mixture at 40 °C, then hydrogenated at 1 bar. The resulting solid was filtered, dried under vacuum at 60 °C to give 34.9 g on **161**, in 94.9% yield. Next, a suspension of 5-methyl-1,3,4-oxadiazole-2-carboxylic acid potassium salt **158** was cooled to 0/5 °C in toluene and DMF. Oxalyl chloride was added gradually over 30 minutes. After 1.5 hours, toluene was partially concentrated under reduced pressure to around 120 mL. Next, the oxadiazole acid chloride formed **159** was added at 50-55 °C to a stirred suspension of **161**, trimethylamine and acetonitrile. For 2 hours, the reaction mixture was stirred at 50-55 °C, then cooled to room temperature. Finally, water, glacial acetic acid and ethyl acetate were added. The crystalline solid was collected by filtration, washed with EtOH and dried to give Raltegravir **162** with 87% efficiency. This approach is both more efficient and more sustainable than what has been mentioned above.

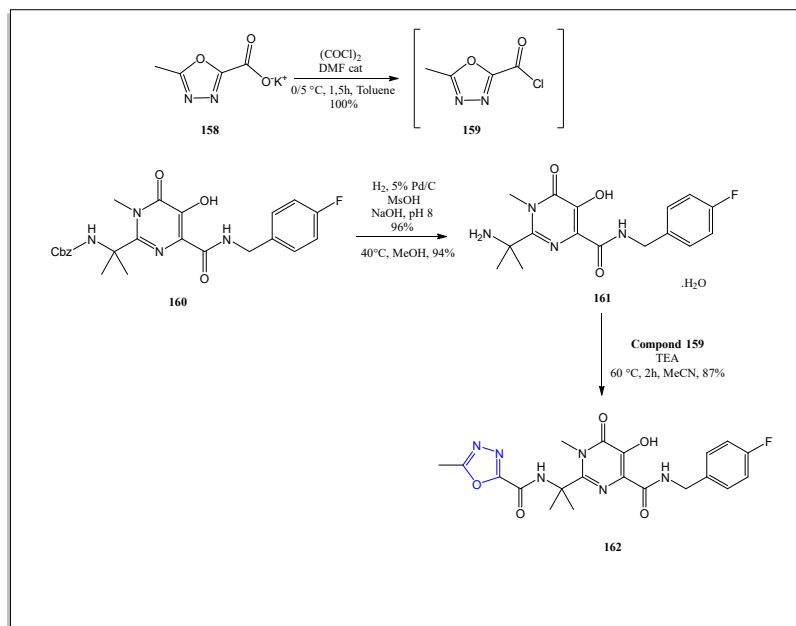

Scheme 39. Synthesis of Raltegravir by *Francesco Caputo et al.*

2-((3,5-Dinitrobenzyl)thio)-5-methyl-1,3,4-oxadiazole was prepared by Galina Karabanovich et al.⁷⁵ First, 3,5-dinitrobenzyl thiocyanate **163** was added to a suspension of sodium azide and triethylammonium chloride in toluene. The reaction mixture was heated at 105 °C for 2 h. After completion of the operation, the precipitate **164** was filtered and washed at neutral pH as a white solid, with a yield of 68%. Then, a solution of 5-((3,5-dinitrobenzyl)sulfanyl)-1H-tetrazole in acetic anhydride was heated at 90 °C for 10 h under microwave irradiation to give **166**, in 60% yield, as a yellowish solid. The *in vitro* activity of this compound was remarkable against *Mycobacterium tuberculosis* CNCTC My 331/88 and six clinically isolated strains of multidrug-resistant *M. tuberculosis*, with minimum inhibitory concentration values as low as 0.03 μM (0.011–0.026 μg/mL). In addition, it demonstrated highly selective antimycobacterial activity as it did not show activity against other bacteria or fungi examined in this study. While this compound demonstrated low *in vitro* toxicity in four proliferating mammalian cell lines and in isolated primary human hepatocytes.

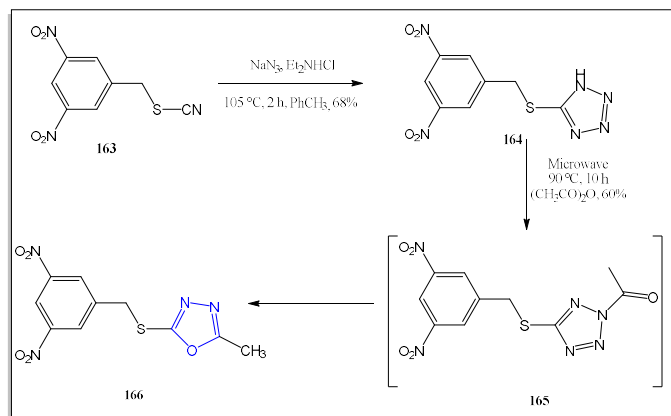

Scheme 40. Synthesis of 2-((3,5-Dinitrobenzyl)thio)-5-methyl-1,3,4-oxadiazole by *Galina Karabanovich et al.*

3. Conclusion

This review summarized the synthesis strategies of 1,3,4-oxadiazole analogs mentioned in latest years, those strategies may want to assist researchers plan a brand new molecule containing the 1,3,4-oxadiazole unit. The main synthesis methods include: cyclodehydration reactions of diacylhydrazines, reaction of hydrazide with carbonyl compound, reaction of hydrazide with aldehydes, reaction of tetrazoles with acids, reaction of hydrazinecarboxamide with aldehydes and many others, using different types of catalysts and solvents. Furthermore, we're assured that 1,3,4-oxadiazole will discover huge packages and retain to draw a whole lot interest in natural synthesis packages given that 1,3,4-oxadiazole analogs constitute a hoop of bonding and a uncooked fabric for lots interactions of artificial chemistry, coordination complicated chemistry and reagents, because of the hybrid atoms they incorporate of their composition, which offers them excessive significance for the reason that they incorporate atoms characterised by way of means of their organic person and pharmacological sports and fundamental nucleus of many important compounds, nutrients and drugs.

Declaration of interest statement

- Conflict of Interest

No conflict of interest exists. We wish to confirm that there are no known conflicts of interest associated with this publication and there has been no significant financial support for this work that could have influenced its outcome.

- Funding

No funding was received for this work.

- Intellectual Property

We confirm that we have given due consideration to the protection of intellectual property associated with this work and that there are no impediments to publication, including the timing of publication, with respect to intellectual property. In so doing we confirm that we have followed the regulations of our institutions concerning intellectual property.

References

1. Arora, P., Arora, V., Lamba, H. S., & Wadhwa, D. (2012). Importance of heterocyclic chemistry: A review. *Int. J. Pharm. Sci. Res.*, 3(9), 2947.
2. Longo Jr, L. S., & Siqueira, F. A. (2024). Synthesis of imidazo [2, 1-b] thiazol-5-amines using Groebke–Blackburn–Bienaymé multicomponent reaction (microreview). *Chem Heterocycl Comp*, 60(7/8),339–341.
3. Lelyukh, M. I., Komarenska, Z. M., Chaban, T. I., & Chaban, I. H. (2024). An overview of the synthetic routes toward [1, 2, 4] triazolo [3, 4-b][1, 3, 4] thiadiazoles (microreview). *Chem Heterocycl Comp*, 60(7/8),342–344.
4. Grinev, V. S., Demeshko, I. A., & Sklyar, A. E. (2024). The synthesis of fluorescent boron difluoride hydrazone (BODIHY) dyes (microreview). *Chem Heterocycl Comp*, 60(5/6),236–238.
5. Chaban, T. I., Klenina, O. V., Chaban, I. H., & Lelyukh, M. I. (2024). Recent advances in the synthesis of thiazolo [4, 5-b] pyridines. part 2: focus on thiazole annulation to pyridine ring. *Chem Heterocycl Comp*, 60(3/4), 130-132.
6. Chaban, T. I., Lelyukh, M. I., Chaban, I. H., & Kasyanchuk, O. Y. (2024). APPROACHES TO THE SYNTHESIS OF THIAZOLO [3, 2-a] PYRIDINES. *Chem Heterocycl Comp*, 60(3/4), 124-126.
7. Bondarenko, S. S., & Lega, D. A. (2024). Recent advances in the chemistry of pyrrolidine-2, 3-diones. *Chem Heterocycl Comp*, 60(3/4), 118-120.
8. Chandrakantha, B., Shetty, P., Nambiyar, V., Isloor, N., & Isloor, A. M. (2010). Synthesis, characterization and biological activity of some new 1, 3, 4-oxadiazole bearing 2-flouro-4-methoxy phenyl moiety. *Eur. J. Med. Chem*, 45(3), 1206-1210.
9. Jones, A. M., & Helm, J. M. (2009). Emerging treatments in cystic fibrosis. *Drugs*, 69, 1903-1910.
10. Boström, J., Hogner, A., Llinàs, A., Wellner, E., & Plowright, A. T. (2012). Oxadiazoles in medicinal chemistry. *J. Med. Chem*, 55(5), 1817-1830.
11. Pitasse-Santos, P., Sueth-Santiago, V., & Lima, M. E. (2018). 1,2,4 and 1,3,4-oxadiazoles as scaffolds in the development of antiparasitic agents. *J. Braz. Chem. Soc.*, 29, 435-456.
12. Khalilullah, H., J Ahsan, M., Hedaitullah, M., Khan, S., & Ahmed, B. (2012). 1, 3, 4-oxadiazole: a biologically active scaffold. *Mini-Rev. Med. Chem.*, 12(8), 789-801.
13. Jones, A. M., & Helm, J. M. (2009). Emerging treatments in cystic fibrosis. *Drugs*, 69, 1903-1910.
14. Khan, B. A., Hamdani, S. S., Khalid, M., Ashfaq, M., Munawar, K. S., Tahir, M. N., Braga. A. A. C., Shawky. A. M., Alqahtani. A. M., Abourehab. M. A. S., Gabr. G. A., Ibrahim. M. A. A., & Sidhom, P. A. (2023). Exploring probenecid derived 1, 3, 4-Oxadiazole-phthalimide hybrid as α -amylase inhibitor: Synthesis, structural investigation, and molecular modeling. *J. Pharm.*, 16(3), 424.

15. Downing, O. A., Wilson, K. A., & Wilson, V. G. (1983). Non-competitive antagonism of the alpha-adrenoceptor-mediated fast component of contraction of rat aorta, by doxazosin and prazosin. *Br. J. Pharmacol.*, 80(2), 315.
16. Li, Y., Liu, J., Zhang, H., Yang, X., & Liu, Z. (2006). Stereoselective synthesis and fungicidal activities of (E)- α -(methoxyimino)-benzeneacetate derivatives containing 1,3,4-oxadiazole ring. *Bioorg. Med. Chem. Lett.* 16(8), 2278-2282.
17. Hamada, N. M. M., & Sharshira, E. M. (2011). Synthesis and antimicrobial evaluation of some heterocyclic chalcone derivatives. *Mol.*, 16(3), 2304-2312.
18. Loetchutinat, C., Chau, F., & Mankhetkorn, S. (2003). Synthesis and evaluation of 5-aryl-3-(4-hydroxyphenyl)-1,3,4-oxadiazole-2-(3H)-thiones as P-glycoprotein inhibitors. *Chem. Pharm. Bull.*, 51(6), 728-730.
19. Abadi, A. H., Eissa, A. A. H., & Hassan, G. S. (2003). Synthesis of novel 1,3,4-trisubstituted pyrazole derivatives and their evaluation as antitumor and antiangiogenic agents. *Chem. Pharm. Bull.*, 51(7), 838-844.
20. Gilani, S. J., Khan, S. A., & Siddiqui, N. (2010). Synthesis and pharmacological evaluation of condensed heterocyclic 6-substituted 1, 2, 4-triazolo-[3, 4-b]-1, 3, 4-thiadiazole and 1, 3, 4-oxadiazole derivatives of isoniazid. *Bioorg. Med. Chem. Lett.*, 20(16), 4762-4765.
21. Mishra, L., Said, M. K., Itokawa, H., & Takeya, K. (1995). Antitumor and antimicrobial activities of Fe (II)/Fe (III) complexes derived from some heterocyclic compounds. *Bioorg. Med. Chem.*, 3(9), 1241-1245.
22. Zheng, Q. Z., Zhang, X. M., Xu, Y., Cheng, K., Jiao, Q. C., & Zhu, H. L. (2010). Synthesis, biological evaluation, and molecular docking studies of 2-chloropyridine derivatives possessing 1, 3, 4-oxadiazole moiety as potential antitumor agents. *Bioorg. Med. Chem.*, 18(22), 7836-7841.
23. Bankar, G. R., Nampurath, G. K., Nayak, P. G., & Bhattacharya, S. (2010). A possible correlation between the correction of endothelial dysfunction and normalization of high blood pressure levels by 1, 3, 4-oxadiazole derivative, an L-type Ca²⁺ channel blocker in deoxycorticosterone acetate and NG-nitro-L-arginine hypertensive rats. *Chem Biol Interact*, 183(2), 327-331.
24. Raman, K., Singh, H. K., Salzman, S. K., & Parmar, S. S. (1993). Substituted thiosemicarbazides and corresponding cyclized 1, 3, 4-oxadiazoles and their anti-inflammatory activity. *J. Pharm. Sci.*, 82(2), 167-169.
25. Sahin, G., Palaska, E., Kelicen, P., Demirdamar, R., & Altinok, G. (2001). Synthesis of some new 1-acylthiosemicarbazides, 1, 3, 4-oxadiazoles, 1, 3, 4-thiadiazoles and 1, 2, 4-triazole-3-thiones and their anti-inflammatory activities. *Arzneimittelforschung*, 51(06), 478-484.
26. Yale, H. L., & Losee, K. (1966). 2-Amino-5-substituted 1, 3, 4-oxadiazoles and 5-imino-2-substituted Δ^2 -1, 3, 4-oxadiazolines. A group of novel muscle relaxants. *J. Med. Chem.*, 9(4), 478-483.
27. Khoramjoui, M., Zarepishe, N., Rezaee, E., Imani, A., Mahmoudzadeh-Mandolakani, R., Hashemi, S., Fallah, M., Hasheminasab, G., Shahhosseini, S., Tabatabai, S. A., & Faizi, M. (2021). Novel derivatives of diphenyl-1, 3, 4-oxadiazole as ligands of benzodiazepine receptors; synthesize, binding assay and pharmacological evaluation. *Iran J Pharm Res*, 20(4), 47.
28. Palmer, J. T., Hirschbein, B. L., Cheung, H., McCarter, J., Janc, J. W., Yu, Z. W., & Wesolowski, G. (2006). Keto-1, 3, 4-oxadiazoles as cathepsin K inhibitors. *Bioorg. Med. Chem. Lett.*, 16(11), 2909-2914.
29. Johns, B. A., Weatherhead, J. G., Allen, S. H., Thompson, J. B., Garvey, E. P., Foster, S. A., Jeffrey, J. L., & Miller, W. H. (2009). The use of oxadiazole and triazole substituted naphthyridines as HIV-1 integrase inhibitors. Part 1: establishing the pharmacophore. *Bioorg. Med. Chem. Lett.*, 19(6), 1802-1806.
30. Khan, M. T. H., Choudhary, M. I., Khan, K. M., & Rani, M. (2005). Atta-ur-rahman. structure-activity relationships of tyrosinase inhibitory combinatorial library of 2, 5-disubstituted-1, 3, 4-oxadiazole analogues. *Bioorg. Med. Chem.*, 13(10), 3385-3395.
31. Khamis, E., Bellucci, F., Latanision, R. M., & El-Ashry, E. S. H. (1991). Acid corrosion inhibition of nickel by 2-(triphenylphosphoranylidene) succinic anhydride. *Corros.*, 47(9), 677-686.
32. Quraishi, M. A., Khan, M. A. W., Jamal, D., & Ajmal, M. (1996). Muralidharan et, S.; Iyer. *J. Appl. Electrochem*, 26, 1253.
33. Quraishi, M. A., Khan, M. W., Ajmal, M., Muralidharan, S., & Iyer, S. V. (1997). Technical note influence of molecular structure of substituted benzothiazoles on corrosion inhibition and hydrogen permeation through mild steel in sulphuric acid. *Br. Corros. J.*, 32(1), 72-76.
34. Memari, B., El Attari, H., Traisnel, M., Bentiss, F., & Lagrenee, M. (1998). Inhibiting effects of 3, 5-bis (n-pyridyl)-4-amino-1, 2, 4-triazoles on the corrosion for mild steel in 1 M HCl medium. *Corros. Sci.*, 40(2-3), 391-399.
35. El Azhar, M., Memari, B., Traisnel, M., Bentiss, F., & Lagrenee, M. (2001). Corrosion inhibition of mild steel by the new class of inhibitors [2, 5-bis (n-pyridyl)-1, 3, 4-thiadiazoles] in acidic media. *Corros. Sci.*, 43(12), 2229-2238.
36. Bentiss, F., Traisnel, M., & Lagrenee, M. (2001). Influence of 2, 5-bis (4-dimethylaminophenyl)-1, 3, 4-thiadiazole on corrosion inhibition of mild steel in acidic media. *J. Appl. Electrochem*, 31(1), 41-48.
37. Wang, L., Yin, G. J., & Yin, J. G. (2001). 2-Mercaptothiazoline and cetyl pyridinium chloride as inhibitors for the corrosion of a low carbon steel in phosphoric acid. *Corros. Sci.*, 43(6), 1197-1202.
38. Rochdi, A., Kassou, O., Dkhireche, N., Touir, R., El Bakri, M., Touhami, M. E., Sfaiir, M., Mernari, B., & Hammouti, B. (2014). Inhibitive properties of 2, 5-bis (n-methylphenyl)-1, 3, 4-oxadiazole and biocide on corrosion, biocorrosion and scaling controls of brass in simulated cooling water. *Corros. Sci.*, 80, 442-452.

39. Salassa, G., & Terenzi, A. (2019). Metal complexes of oxadiazole ligands: an overview. *Int. J. Mol. Sci.*, 20(14), 3483.
40. Xu, Z., Li, Y., Ma, X., Gao, X., & Tian, H. (2008). Synthesis and properties of iridium complexes based 1, 3, 4-oxadiazoles derivatives. *Tetrahedron*, 64(8), 1860-1867.
41. Rasool, N., Razaq, Z., Khan, S. G., Javaid, S., Akhtar, N., Mahmood, S., Christensen, J. B., Altaf, A. A., Anjum, S. M., Alqahtani, F., AlAsmari, A., & Imran, I. (2023). A facile synthesis of 1, 3, 4-oxadiazole-based carbamothioate molecules: Antiseizure potential, EEG evaluation and in-silico docking studies. *Arab. J. Chem.*, 16(4), 104610.
42. Tolan, H. E., Fahim, A. M., & Ismael, E. H. (2023). Synthesis, biological activities, molecular docking, theoretical calculations of some 1, 3, 4-oxadiazoles, 1, 2, 4-triazoles, and 1, 2, 4-triazolo [3, 4-b]-1, 3, 4-thiadiazines derivatives. *J. Mol. Struct.*, 1283, 135238.
43. Fan, C., Chen, J., Xu, Z., Yin, P., Wu, C., & Sun, T. (2024). Synthesis, crystal structure, anti-tuberculosis activity and toxicity prediction of N-(4-bromophenyl)-3-(5-(4-chloro-3-nitrophenyl)-1, 3, 4-oxadiazol-2-yl) benzenesulfonamide. *J. Mol. Struct.*, 1297, 136901.
44. Alzahrani, A. Y. A., Ullah, H., Bhat, M. A., Rahim, F., Al-Wesabi, E. O., & Alanazi, T. Y. (2024). Design, synthesis, in vitro acetylcholinesterase, butyrylcholinesterase activities, and in silico molecular docking study of oxindole-oxadiazole hybrid analogues. *J. Mol. Struct.*, 1299, 137167.
45. Thongolla, R., Pulabala, R., Gogula, S. S., Shenoy, T. N., Salam, A. A. A., Vankadari, S. R., Rondla, R., & Puchakayala, M. R. (2024). Design, synthesis, and molecular docking studies of new phenanthrene-linked oxadiazoles as potential antimicrobial agents. *J. Mol. Struct.*, 1300, 137260.
46. Bhukta, S., Chatterjee, R., Angajala, K. K., & Dandela, R. (2023). Iodine-mediated domino cyclization of hydrazides for one-pot synthesis of 1, 3, 4-oxadiazoles via oxidative bond cleavage of vinyl azide. *TETL*, 128, 154714.
47. Doddagaddavalli, M. A., Kalalbandi, V. K. A., Seetharamappa, J., & Joshi, S. D. (2024). New thiophene-1, 3, 4-oxadiazole-thiazolidine-2, 4-dione hybrids: synthesis, MCF-7 inhibition and binding studies. *Bioorg. Chem.*, 143, 107003.
48. Peng, J., Zhang, Y., Liu, X., Zou, Y., Song, H., Wang, S., Cai, Q., Chen, J., & Hu, D. (2023). Design, synthesis, antibacterial activity, and mechanism of novel resveratrol derivatives containing an 1, 3, 4-oxadiazole moiety. *Pestic Biochem Physiol.*, 193, 105457.
49. Xie, W., & Li, L. (2024). Preparation and properties of modified POD membranes by polycarboxylic acids copolymerization. *React. Funct. Polym.*, 105829.
50. Gastaldi, S., Rocca, C., Gianquinto, E., Granieri, M. C., Boscaro, V., Blua, F & Angelone, T. (2023). Discovery of a novel 1, 3, 4-oxadiazol-2-one-based NLRP3 inhibitor as a pharmacological agent to mitigate cardiac and metabolic complications in an experimental model of diet-induced metaflammation. *Eur. J. Med. Chem.*, 115542.
51. Hossan, A., Abumelha, H. M., Alnoman, R. B., Bayazeed, A., Alsoliemy, A., Keshk, A. A., & El-Metwaly, N. M. (2022). Synthesis, self-assembly and optical properties of novel fluorescent alkoxy-substituted fluoroaryl 1, 3, 4-oxadiazole organogelator. *Arab. J. Chem.*, 15(5), 103771.
52. Kumar, P. B. R., Kadiri, S. K., Khobragade, D. S., Priya, R. V., Veni, C. K., Srilakshmi, S., & Tiwari, P. (2024). Synthesis, characterization and biological investigations of some new Oxadiazoles: In-vitro and In-Silico approach. *Results Chem.*, 7, 101241.
53. Bisht, A. S., & Juyal, D. (2024). Synthesis and bioactive investigation of amino acids fused 1, 3, 4-oxadiazole derivatives as unnatural amino Acids. *Ind. J. Pharm. Edu. Res.*, 58(1), 1-6.
54. Mahanty, K., Halder, A., & De Sarkar, S. (2023). Synthesis of N-sulfonyl amidines and 1, 3, 4-oxadiazoles through electrochemical activation of DMF. *Adv. Synth. Catal.*, 365(1), 96-103.
55. König, B., Watson, P. R., Reßing, N., Cragin, A. D., Schäker-Hübner, L., Christianson, D. W., & Hansen, F. K. (2023). Difluoromethyl-1, 3, 4-oxadiazoles are selective, mechanism-based, and essentially irreversible inhibitors of histone deacetylase 6. *J. Med. Chem.*, 66(19), 13821-13837.
56. Lachhab, S., Oubella, A., Mehdi, A., Neyts, J., Jochmans, D., Chiu, W., Vangeel, L., Jonghe, S. D., Morjani, H., Ali, M. A., Zanouily, M., Sanghvi, Y. S., & Lazrek, H. B. (2023). Synthesis, characterization, molecular docking, and anticancer activities of new 1, 3, 4-oxadiazole-5-fluorocytosine hybrid derivatives. *J. Mol. Struct.* 1272, 134135.
57. Hashem, H. E., Ahmad, S., Kumer, A., & Bakri, Y. E. (2024). In silico and in vitro prediction of new synthesized N-heterocyclic compounds as anti-SARS-CoV-2. *Sci. Rep.*, 14(1), 1152.
58. He, S., Wang, C., Cheng, Z., Li, X., Si, Z., Huang, Y., Chen, L., & Zhang, Y. (2024). Synthesis and application of dithiocarbamate oxadiazole thione for flotation separation of malachite from quartz and calcite. *Adv. Powder Technol.*, 35(1), 104315.
59. Alaasar, M., Darweesh, A. F., Cao, Y., Iakoubovskii, K., & Yoshio, M. (2024). Electric field-and light-responsive oxadiazole bent-core polycatenar liquid crystals. *J. Mater. Chem. C*, 12(4), 1523-1532.
60. Lu, A., Zheng, Y., Li, T., Wang, J., & Song, G. (2024). Structural diversity derivatization and studies on the nematocidal activity of tropane derivatives. *Phytochem. Lett.*, 59, 108-116.

61. Bhandari, S. V., Nagras, O. G., Kuthe, P. V., Sarkate, A. P., Waghmare, K. S., Pansare, D. N., Chaudhari, S., Y., Mawale, S. N., & Belwate, M. C. (2023). Design, synthesis, molecular docking and antioxidant evaluation of benzimidazole-1, 3, 4 oxadiazole derivatives. *J. Mol. Struct.*, 1276, 134747.
62. Balogh, R., Eckstein, A., Tokár, K., & Danko, M. (2023). The synthesis and spectral study of thiazolo [5, 4-d] thiazole based small molecules using 1, 3, 4-oxadiazole as a linker for organic electronics. *J. Photochem Photobiol A Chem*, 434, 114217.
63. Oliveira, M. S., Santos, A. B., Ferraz, T. V., Moura, G. L., & Falcão, E. H. (2023). Non-symmetrical 1, 3, 4-oxadiazole derivatives: synthesis, characterization, and computational study of their optical properties. *Chem. Phys. Impact*, 6, 100162.
64. Pflégr, V., Stolaříková, J., Pál, A., Korduláková, J., & Krátký, M. (2023). Novel pyrimidine-1, 3, 4-oxadiazole hybrids and their precursors as potential antimycobacterial agents. *Future Med. Chem.*, 15(12), 1049-1067.
65. Zheng, X., Yan, T., Cheng, G., & Yang, H. (2023). An advanced zwitterionic compound based on dinitropyrazole and 1, 3, 4-oxadiazole: combining the high detonation performances and low sensitivities. *J. Chem. Eng.*, 460, 141654.
66. Verdoorn, D. S., Ranjan, P., De Reuver, T., Janssen, E., Vande Velde, C. M., Saya, J. M., Maes, B. U., & Orru, R. V. (2023). A Cobalt mediated nitrene transfer aza-wittig cascade reaction to access 1, 3, 4-oxadiazole scaffolds. *Org. Lett.*, 25(22), 4005-4009.
67. Alharthi, A. I., Alotaibi, M. A., AbdelFattah, E., Akela, M. A., Ali, I., Nassar, A. A., & Bakht, M. A. (2023). Facile catalytic construction of one-pot two-component 1, 3, 4-oxadiazole derivatives over Zn promoted Cu/CeO₃ catalysts in semi-aqueous condition. *J. Mol. Struct.*, 1291, 136004.
68. Meng, H. W., Shen, Z. B., Meng, X. S., Yin, Z. Q., Wang, X. R., Zou, T. F., Liu, Z. G., Wang, T. X., Zhang, S., Chen, Y. L., Yang, X. X., Li, Q. S., & Duan, Y. J. (2023). Novel flavonoid 1, 3, 4-oxadiazole derivatives ameliorate MPTP-induced parkinson's disease via Nrf2/NF-κB signaling pathway. *Bioorg. Chem.*, 106654.
69. Karabelyov, V., Angelova, V. T., Sharkov, M., Mihaylova, R., Popov, G., Pencheva, T., Manov, V., Dangalov, M., Todorova, N., & Kondeva-Burdina, M. (2023). In vitro/in vivo effects of some new 2, 5-disubstituted 1, 3, 4-oxadiazole and hydrazone analogues targeting Parkinson's disease. *J. Mol. Struct.*, 1288, 135755.
70. Rezaee, E., Ahmadi, F., Shabaninia, M., Khoramjouy, M., Farsani, Z. A., Shahhosseini, S., Tabatabai, S. A., & Faizi, M. (2023). Novel 2-substituted-5-(4-chloro-2-phenoxy) phenyl-1, 3, 4-oxadiazole derivatives, ligands of GABAA/benzodiazepine receptor complex: design, synthesis, radioligand binding assay, and pharmacological evaluation. *EXCLI J.*, 22,
71. Maruthesh, H., Katagi, M. S., Samuel, J., Aladakatti, R. H., & Nandeshwarappa, B. P. (2023). Synthesis and characterization of substituted 5-(2-Chloroquinolin-3-yl)-1, 3, 4-oxadiazole-2-amines: computational, in silico ADME, molecular docking, and biological activities. *Russ. J. Bioorg. Chem.*, 49(6), 1422-1437.
72. Syeda, A. B., Ferazoddin, M., Rajeswari, M., Paul, J. P., & Juluru, B. (2023). Design, synthesis and anticancer evaluation of benzoxazole resemble substituted arylamide derivatives of bis-1, 3, 4-oxadiazole-oxazolo [4, 5-b] pyridin-2-yl) as anticancer agents. *Chem. Data Collect.*, 43, 100971.
73. Naik, L., Thippeswamy, M. S., Praveenkumar, V., Malimath, G. H., Ramesh, D., Sutar, S., Savanur, H. M., Gudennavar, S. B., & Bubbly, S. G. (2023). Solute-solvent interaction and DFT studies on bromonaphthofuran 1, 3, 4-oxadiazole fluorophores for optoelectronic applications. *J. Mol. Graph. Model.* 118, 108367.
74. Caputo, F., Corbetta, S., Piccolo, O., & Vigo, D. (2020). Seeking for selectivity and efficiency: new approaches in the synthesis of raltegravir. *Org. Process Res. Dev.*, 24(6), 1149-1156.
75. Karabanovich, G., Zemanová, J., Smutný, T., Székely, R., Šarkan, M., Centárová, I., Vocat, A., Pavkova, I., Conka, P., Nemecek, J., Stolarikova, J., Vejsova, M., Vavrova, K., Klimesova, V., Hrabalek, A., Pavek, P., Cole, S. T., Mikusova, K., & Roh, J. (2016). Development of 3, 5-dinitrobenzylsulfanyl-1, 3, 4-oxadiazoles and thiadiazoles as selective antitubercular agents active against replicating and nonreplicating Mycobacterium tuberculosis. *J. Med. Chem.*, 59(6), 2362-2380



© 2025 by the authors; licensee Growing Science, Canada. This is an open access article distributed under the terms and conditions of the Creative Commons Attribution (CC-BY) license (<http://creativecommons.org/licenses/by/4.0/>).